

DEPARTMENT OF THE ARMY TECHNICAL MANUAL

**Organizational Maintenance Manual
(Including Repair Parts And Special Tools List)
For**

**LAUNCHER, PROJECTILE, 64 MILLIMETER:
RIOT CONTROL, M234
(1010-01-014-6506)**

This copy is a reprint which includes current pages from Change 1.

HEADQUARTERS, DEPARTMENT OF THE ARMY

December 1981

ALPHABETICAL INDEX
PAGE INDEX 1

ESML
PAGE D-1

RPSTL
PAGE C-1

MAC
PAGE B-1

TROUBLE-SHOOTING
PAGE 2-7

PMCS
PAGE 2-3

MAINTENANCE INSTRUCTIONS
PAGE 2-1

INTRODUCTION
PAGE 1-1

WARNING

Aline manifold groove with slot in top of launcher body. The manifold retaining pin will then fit in groove and will keep launching cup and attached parts from being expelled when launcher is fired. Failure to comply could cause injury to personnel.

FIRST AID

For first aid information, refer to FM 21-11.

CHANGE

No. 1

**Organizational Maintenance Manual
(Including Repair Parts and Special Tools List)**

for

**LAUNCHER, PROJECTILE, 64 MILLIMETER: RIOT CONTROL, M234
(1010-01-014-6506)**

TM 9-1010-224-20&P, 18 December 1981, is changed as follows:

1. Remove old pages and insert new pages as indicated below.
2. New or changed material is indicated by a vertical bar in the margin of the page.
3. New or changed illustrations are indicated by a miniature pointing hand highlighting the change.

Remove Pages

i and ii
1-1 and 1-2
2-1 and 2-2
None
2-3 and 2-4
A-1 (A-2 blank)
D-1 and D-2

Insert Pages

i and ii
1-1 and 1-2
2-1 and 2-2
2-2.1(2-2.2 blank)
2-3 and 2-4
A-1 (A-2 blank)
D-1 and D-2

File this change sheet in back of the publication for reference purposes.

By Order of the Secretary of the Army:

JOHN A. WICKHAM, JR.
General, United States Army
Chief of Staff

Official:

MILDRED E. HEDBERG
Brigadier General, United States Army
The Adjutant General

DISTRIBUTION:

To be distributed in accordance with DA Form 12-40, Organizational Maintenance requirements for Launcher, Riot Control, 64-MM, M234.

**Organizational Maintenance Manual
 (Including Repair Parts and Special Tools List)
 for
 LAUNCHER, PROJECTILE, 64 MILLIMETER: RIOT CONTROL, M234
 (1010-01-014-6506)**

Current as of 17 July 1981

REPORTING ERRORS AND RECOMMENDING IMPROVEMENTS

You can help improve this manual. If you find any mistakes or if you know of a way to improve the procedures, please let us know. Mail your letter, DA Form 2028 (Recommended Changes to Publications and Blank Forms), or DA Form 2028-2, located in the back of this manual direct to: Commander, US Army Armament, Munitions and Chemical Command: ATTN: AMSMC-MAS, Rock Island, IL 61299-6000. A reply will be furnished to you.

		Page
HOW TO USE THIS MANUAL		iii
CHAPTER	1	
	INTRODUCTION	
	Chapter Index	1-1
Section	I. General Information	1-1
Section	II. Equipment Description and Data	1-3

			Page
CHAPTER	2	MAINTENANCE INSTRUCTIONS	
		Chapter Index	2-1
Section	I.	Repair Parts, Special Tools, TMDE, and Support Equipment	2-1
Section	II.	Service Upon Receipt	2-2
Section	III.	Preventive Maintenance Checks and Services (PMCS) I.....	2-3
Section	IV.	Troubleshooting	2-6
Section	V.	Maintenance Procedures	2-9
Section	VI.	Preparation for Storage or Shipment	2-25
APPENDIX	A	REFERENCES	A-1
APPENDIX	B	MAINTENANCE ALLOCATION CHART	
Section	I.	Introduction	B-1
Section	II.	Maintenance Allocation Chart for M234 Launcher.....	B-4
Section	III.	Tool and Test Equipment Requirements for M234 Launcher	B-4
Section	IV.	Remarks (not applicable)	B-4
APPENDIX	C	REPAIR PARTS AND SPECIAL TOOLS LIST	
Section	I.	Introduction	C-1
Section	II.	Repair Parts List	C-4
Group	00	Launcher, Projectile, 64 Millimeter: Riot Control, M234.....	C-5
Section	III.	Special Tools List (not applicable)	C-6
Section	IV.	National Stock Number and Part Number Index	C-6
APPENDIX	D I	EXPENDABLE/DURABLE SUPPLIES AND MATERIALS LIST	
Section	I.	Introduction	D-1
Section	II.	Expendable/Durable Supplies and Materials List	D-2
		ALPHABETICAL INDEX	Index 1

HOW TO USE THIS MANUAL

MANUAL OVERVIEW

This manual covers organizational level maintenance, repair, and replacement of parts for the launcher, projectile, 64 millimeter: riot control, M234. Chapter 1 introduces the launcher, projectile, 64 millimeter: riot control, M234. Chapter 2 gives the maintenance instructions. Illustrations are provided for each step in the maintenance procedure.

GENERAL

Become familiar with the maintenance procedure before beginning the maintenance task.

References in the manual are to pages, paragraphs, or to other publications.

INDEXES

This manual has several useful indexes to help the user quickly find the information needed:

- a. **Front Cover Index.** Is a tabbed index of chapters and appendixes. Keyed to tabbed pages in the manual.
- b. **Table of Contents.** Lists in order all chapters, sections, appendixes, and index. Gives page references.
- c. **Official Nomenclature, Names, and Designations.**
 - (1) **Nomenclature Cross-Reference List.** Gives an alphabetical list of common names and official

nomenclature used in the manual.

- (2) **List of Abbreviations.** Is an alphabetical list of uncommon abbreviations used in the manual.
- d. **Chapter Indexes.** Located at the beginning of each chapter. Paragraph titles are listed in alphabetical order. Gives paragraph references.
- e. **Alphabetical Index.** Located at the end of the manual. An extensive subject index for everything in the manual. Gives page references.

MAINTENANCE PROCEDURES

Paragraph 2-10 is a summary procedure. Detailed procedures for the maintenance task begin with paragraph 2-11.

- a. **Summary Procedure.** Made up of two parts-initial setup and list of tasks. (See para 2-10.) Used only when doing maintenance on the launcher, projectile, 64 millimeter: riot control, M234. (For maintenance of an individual part, use the detailed procedures following the summary procedure.)
 - (1) **Initial Setup.** Is a list of everything needed in order to do the maintenance task:

HOW TO USE THIS MANUAL (cont)

MAINTENANCE PROCEDURES (cont)

- Tools.....Lists tools needed in maintenance.
- Materials/Parts.....Lists expendable materials and references appendix D.
- Personnel Required.....Lists personnel required to do the task.
- References.....Lists other publications containing necessary information.
- Troubleshooting ReferencesLists malfunctions which can be corrected by following the maintenance procedure.

(2) **Lists of Tasks.** Summarizes the tasks in outline form. Gives page references to detailed procedures.

b. **Detailed Procedures.** Immediately follow the summary procedure. Also contain an initial setup plus step-by-step procedures.

(1) **Initial Setup.** Items needed to perform the maintenance task are listed.

(2) **Step-By-Step Procedures.** Are illustrated procedures for maintenance authorized in the Maintenance Allocation Chart (MAC) (app B) and the Repair Parts and Special Tools List (RPSTL) (app C). Always remember this, complete disassembly is seldom necessary to make a repair. Use good judgment to keep extent of disassembly to a minimum.

REPAIR PARTS AND SPECIAL TOOLS LIST

a. **Repair Parts and Special Tools.** Designed for organizational maintenance repair and general use. Listed in appendix C.

b. **Illustrations.** Accompany the repair parts list and the special tools list.

CHAPTER 1
INTRODUCTION

CHAPTER INDEX

	Paragraph
Destruction of Army Materiel to Prevent Enemy Use	1-3
Equipment Characteristics, Capabilities, and Features.....	1-7
Equipment Data.....	1-9
Location and Description of Major Components	1-8
Maintenance Forms, Records, and Reports	1-2
Official Nomenclature, Names, and Designations	1-5
Preparation for Storage or Shipment.....	1-4
Reporting Equipment Improvement Recommendations (EIR)	1-6
Scope.....	1-1

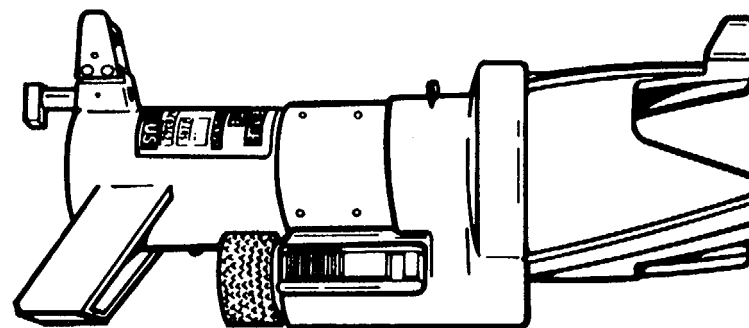

Section I. GENERAL INFORMATION

1-1. SCOPE

- a. **Type of manual:** Organizational maintenance.
- b. **Model number and equipment name:** Launcher, Projectile, 64 Millimeter: Riot Control, M234.
- c. **Purpose of equipment:** Attaches to the M16A1 rifle and launches a riot control projectile.

1-2. MAINTENANCE FORMS, RECORDS, AND REPORTS

- a. Department of the Army forms and procedures used for equipment maintenance will be those prescribed by DA PAM 738-750, as contained in Maintenance Management Update.
- b. Accidents involving injury to personnel or damage to materiel will be reported on DA Form 285 (Accident Report) in accordance with AR 385-40 Explosive and ammunition malfunctions will be reported in accordance with AR 75-1.

1-3. DESTRUCTION OF ARMY MATERIEL TO PREVENT ENEMY USE

Refer to TM 750-244-7 for instructions.

1-4. PREPARATION FOR STORAGE OR SHIPMENT

Refer to instructions in paragraph 2-12

1-5. OFFICIAL NOMENCLATURE, NAMES, AND DESIGNATIONS

This listing includes the nomenclature cross-reference list and the list of abbreviations used in this manual.

a. NOMENCLATURE CROSS-REFERENCE LIST.

Common Name	Official Nomenclature
Buffer	Buffer, recoil mechanism
Cylindrical spring	Spring, helical, compression
Detent spring pin	Pin, spring
Launching cup	Cup, projectile launching
Lock-release pin	Pin, spring
Lock-release spring	Spring, helical, compression
Manifold	Manifold, projectile
M234 launcher	Launcher, projectile, 64 millimeter: riot control, M234
Retainer	Retainer, helical compression spring
Retaining plate	Plate, retaining, launcher cup
Rifle bore cleaner (RBC)	Cleaning compound, rifle bore
Stop screw	Screw, machine

b. ABBREVIATIONS.

LSA.....	Lubricating Oil, Semi-fluid, Automatic Weapons
MTOE.....	Modified Table of Organization and Equipment
PMCS.....	Preventive Maintenance Checks and Services

1-6. REPORTING EQUIPMENT IMPROVEMENT RECOMMENDATIONS (EIR)

If your M234 launcher needs improvement, let us know. Send us an EIR. You, the user, are the only one who can tell us what you don't like about your equipment. Let us know why you don't like the design. Put it on an SF 368 (Quality Deficiency Report). Mail it to us at Commander, US Army Armament, Munitions and Chemical Command, ATTN: AMSMC-QAD, Rock Island, IL 61299-6000. A reply will be furnished to you.

Section II. EQUIPMENT DESCRIPTION AND DATA

1-7. EQUIPMENT CHARACTERISTICS, CAPABILITIES, AND FEATURES

The M234 launcher is a portable lightweight, easily maintained piece of equipment. It attaches to an M16A1 rifle or a modified M16 rifle equipped with a closed-end flash suppressor. It launches a riot control projectile and is actuated by firing the M755 blank cartridge.

1-8. LOCATION AND DESCRIPTION OF MAJOR COMPONENTS

The M234 launcher is held onto the forward end of the barrel of the rifle by a lock-release sleeve and two lock-release levers, one located on each side. To keep the launcher from turning, the arm mates with the rifle forward sight guard, and the buffer housing mates with the rifle bayonet stud. The launching cup travels in the launcher body and is retained by the manifold retaining pin and the groove in the manifold. The launcher is aimed by using the front and rear sights. The launching cup is held in the rear position by the detent.

1-9. EQUIPMENT DATA

See TM 9-1010-224-10: Operator's Manual, Launcher, Projectile, 64 Millimeter: Riot Control, M234 for performance data.

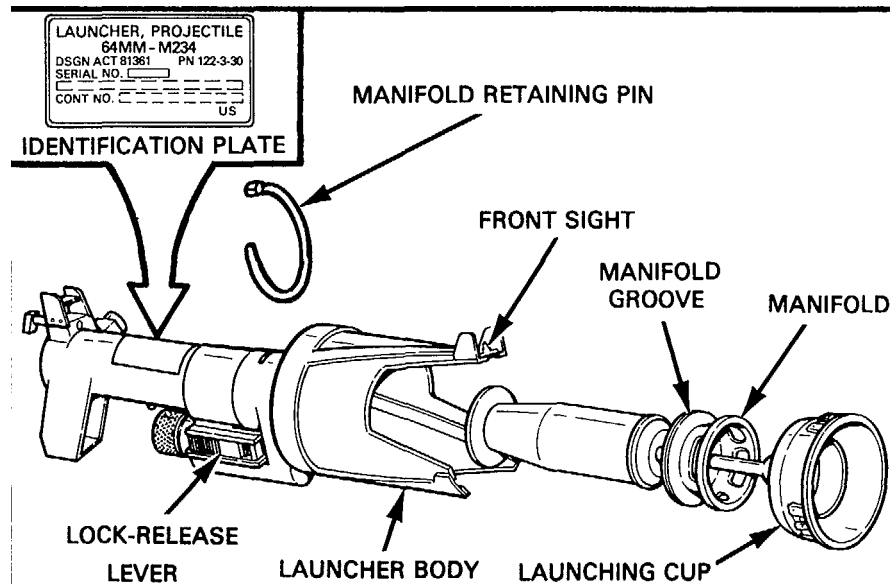
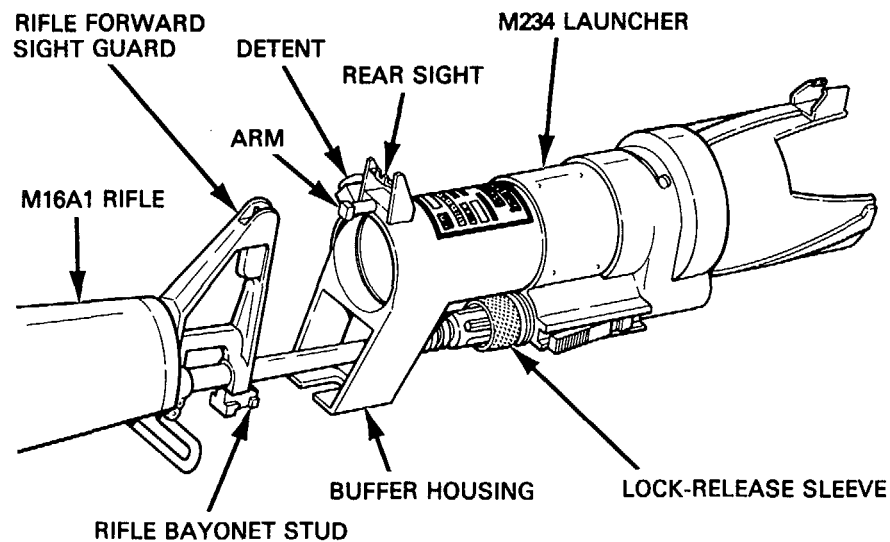

1-9. EQUIPMENT DATA (cont)

	US CUSTOMARY	METRIC
M234 Launcher:		
Length	10.9 in.	(27.69 cm)
Weight	2.06 lb	(0.93 kg)
Width	3.4 in.	(8.64 cm)
Shipping Containers:		
Carriers (four per container):		
Height	9.12 in.	(23.16 cm)
Length	14.82 in.	(37.64 cm)
Weight (loaded)	16 lb	(7.20 kg)
Width	8.56 in.	(21.74 cm)
M234 Launcher (one per container):		
Height	9.12 in.	(23.16 cm)
Length	14.82 in.	(37.64 cm)
Weight (loaded)	12.6 lb	(5.72 kg)
Width	8.56 in.	(21.74 cm)

**CHAPTER 2
MAINTENANCE INSTRUCTIONS**

CHAPTER INDEX

	Paragraph		Paragraph
Checking Unpacked Equipment	2-5	Preparation For Storage or Shipment	2-12
Common Tools and Equipment	2-1	Preventive Maintenance Checks and Services	2-6
General.....	2-7	Repair Parts	2-3
Introduction	2-9	Service Upon Receipt-M234 Launcher	2-4
M234 Launcher-Maintenance Instructions	2-11	Special Tools, TMDE, and Support Equipment	2-2
M234 Launcher-Summary Procedure	2-10	Troubleshooting.....	2-8

Section I. REPAIR PARTS, SPECIAL TOOLS, TMDE, AND SUPPORT EQUIPMENT

2-1. COMMON TOOLS AND EQUIPMENT

For authorized common tools and equipment, refer to the Modified Table of Organization and Equipment (MTOE) applicable to your unit.

2-2. SPECIAL TOOLS, TMDE, AND SUPPORT EQUIPMENT

No special tools or equipment are required for maintenance of the M234 launcher.

2-3. REPAIR PARTS

Repair parts are listed and illustrated in appendix C of this manual.

Section II. SERVICE UPON RECEIPT

2-4. SERVICE UPON RECEIPT-M234 LAUNCHER

LOCATION	ITEM	ACTION	REMARKS
M234 launcher	a. All external parts	<p style="text-align: center;">NOTE</p> <p>Do not discard wooden box and plastic foam cushions. They will be used for storage and shipment of the M234 launcher.</p> <p>Inspect for cracks, broken, or missing parts.</p>	Paragraph 2-5
	b. Launching cup	<p style="text-align: center;">NOTE</p> <p>Some resistance to movement of the launching cup may be felt on new launchers. Cup should be readily moved by hand through travel distance without binding.</p> <p>a. Check for binding.</p> <p>b. Check for presence of proof mark "X". If absent, proof fire as follows:</p> <p>(1) Install M234 launcher to M16A1 rifle. (2) Prepare rifle and launcher for firing.</p> <p style="text-align: center;">NOTE</p> <p>Fire projectile into a soft recovery area. Projectiles can be reused if breakband remains intact.</p>	<p>Table 2-2, malfunction 1.</p> <p>Table 2-1, malfunction 3.</p> <p>TM 9-1010-224-10.</p>

- c. Fire one projectile into recovery area.
- d. Recover projectile
- e. Remove launcher cap.
- f. Inspect launcher cup for evidence of cracks, cracked or loose keys, or separation of the braze joints at either end of the cup shaft.

Paragraph 2-11

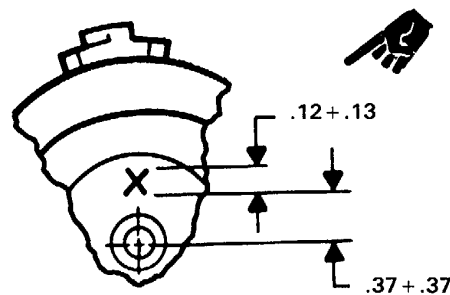

- g. Etch proof mark "X" on inner face of launching cup as illustrated.
- h. Clean and reassemble.

NOTE

Do not lubricate inside launcher body rearward of grooves.

c. Launcher body

Lightly lubricate inside launcher body and grooves with LSA (item 3, app D).

12-5. CHECKING UNPACKED EQUIPMENT

a. Inspect the equipment for damage incurred during shipment. If the equipment has been damaged, report the damage on DD Form 6, Packaging Improvement Report.

b. Check the equipment to see if the shipment is complete. Report all discrepancies in accordance with the instructions in DA PAM 738-750.

Section III. PREVENTIVE MAINTENANCE CHECKS AND SERVICES (PMCS)

2-6. PREVENTIVE MAINTENANCE CHECKS AND SERVICES

Table 2-1 lists checks and services to be performed semiannually on the M234 launcher. The item number corresponds to the order in which the

checks and services should be performed. Numbers on the following figure correspond to the item number. Replace all damaged and missing parts.

Change 1 2-3

Table 2-1. PREVENTIVE MAINTENANCE CHECKS AND SERVICES SEMIANNUAL SCHEDULE

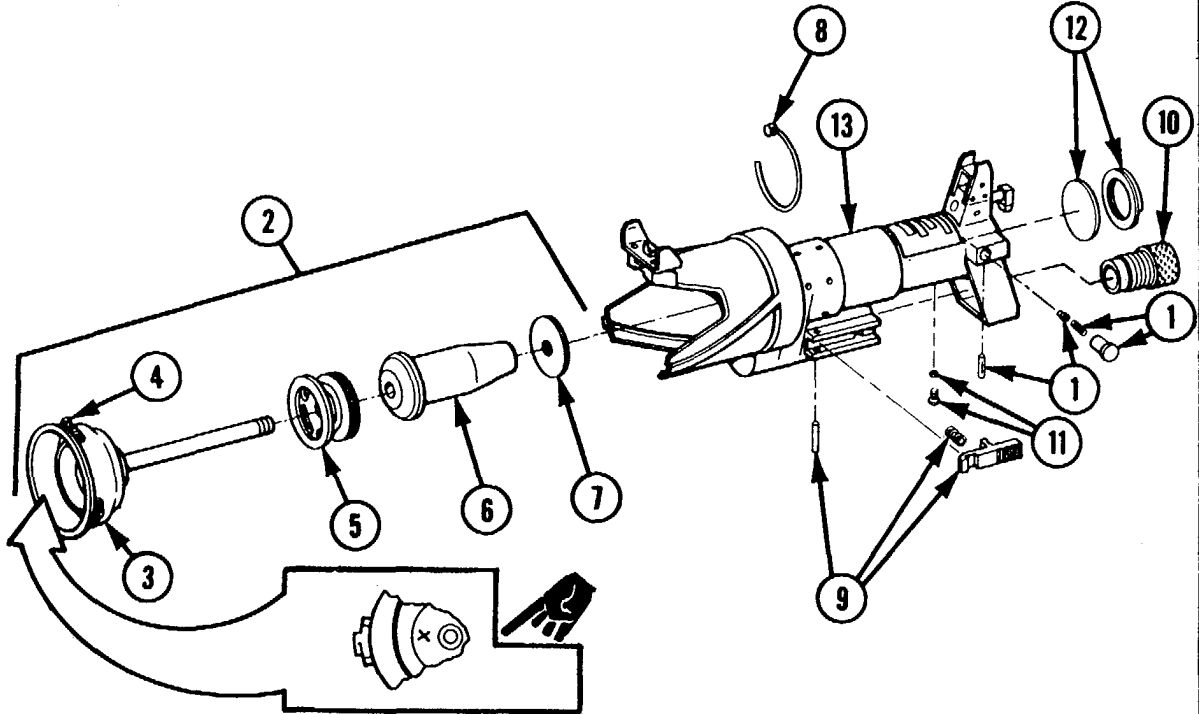
Item No.	Item to be inspected	Procedures
<p>1</p> <p>2</p> <p>3.</p>	<p>Detent spring pin, detent cylindrical spring, and retainer</p> <p>Launching cup and attached parts</p> <p>Launching cup and shaft</p>	 <p>Push launching cup to rear of launcher, then pull forward to check if detent holds launching cup in rear position. Remove if inoperable (para 2-11, disassembly, steps 5 and 6). Inspect for cracks, breaks, and dents.</p> <p>Remove and disassemble (para 2-11 disassembly, steps 1 thru 4).</p> <p>a. Inspect cup for dents. Check shaft for bends and crossed threads. b. Inspect for missing proof mark "X".</p>

4	Keys	Inspect keys for cracks, looseness, or wear to the edge of the center rivet head.
5	Manifold	Inspect for cracks and chipped edges.
6	Buffer	Inspect for cracks.
7	Retaining plate	Inspect for cracks and crossed threads.
8	Manifold retaining pin	Inspect for kinks and missing handle.
9	Lock-release levers, lock release springs, and lock-release pins	Inspect to see that springs open the lock-release levers. Remove only if lock-release levers are damaged or inoperable (para 2-11 disassembly, steps 9 and 11). Inspect for cracks, breaks, and dents.
10	Lock-release sleeve	Inspect for cracks and crossed threads. Remove only if necessary to replace (para 2-11 disassembly, steps 7 and 8).
11	Stop screw and washer	Inspect to see if present.
12	Bulkhead and retaining ring	Inspect for cracks and breaks. Remove only if necessary to replace (para 2-11 disassembly, steps 12 and 13).
13	Launcher body	Inspect for cracks and dents. Inspect for broken, dented, or missing front or rear sights.
	M234 Launcher	Clean disassembled parts (para 2-11, cleaning), lubricate (para 2-11, lubrication), and reassemble (para-2-11, reassembly).

Section IV. TROUBLESHOOTING

2-7. GENERAL

The symptom index will help in locating most malfunctions.

SYMPTOM INDEX

	Troubleshooting Procedure (Paragraph)
LAUNCHING CUP	
Fails to remain in rear position.....	2-8
Will not move freely	2-8
MANIFOLD RETAINING PIN	
Is difficult to remove or install	2-8
M234 LAUNCHER	
Is loose on rifle barrel	2-8
PROJECTILE	
Flight is erratic.....	2-8

2-8. TROUBLESHOOTING

Table 2-2 lists the common malfunctions which may be found during maintenance or operation of the M234 launcher. Perform the tests or

inspections and corrective actions in the order listed. If a malfunction is not listed or is not corrected by listed corrective action, notify the supervisor.

Table 2-2. TROUBLESHOOTING

<p>MALFUNCTION</p> <p>TEST OR INSPECTION</p> <p>CORRECTIVE ACTION</p>	<p>LOCATION</p>
<p style="text-align: center;">NOTE</p> <p>For disassembly and reassembly of parts mentioned in the troubleshooting table, see paragraph 2-11.</p> <p>1. LAUNCHING CUP WILL NOT MOVE FREELY.</p> <p>Step 1. Check for cracks in buffer (1). Replace buffer.</p> <p>Step 2. Check for cracked or chipped manifold (2). Replace manifold.</p> <p>Step 3. Check for bent or dented launching cup (3). Replace launching cup.</p> <p>Step 4. Check for cracked or dented retaining plate (4). Replace retaining plate.</p> <p>Step 5. Check for broken or bent shaft (5). Replace launching cup.</p> <p>Step 6. Check for broken or bent keys (6). Replace launching cup.</p>	 <p>The diagram shows an exploded view of a launching cup assembly. At the top, a perspective view shows the assembled components: a buffer (1) on a shaft (5) passing through a manifold (2) and a launching cup (3). A retaining plate (4) is positioned behind the cup. Below this, an exploded view shows the individual parts: the manifold (2) on the left, the shaft (5) in the middle, and the retaining plate (4) on the right. Numbered callouts 1 through 6 point to the specific parts mentioned in the troubleshooting steps.</p>

Table 2-2. TROUBLESHOOTING (cont)

<p>MALFUNCTION</p> <p>TEST OR INSPECTION</p> <p>CORRECTIVE ACTION</p>	<p>LOCATION</p>
<p>2. LAUNCHING CUP FAILS TO REMAIN IN REAR POSITION.</p> <p>Step 1. Check for broken detent spring (7). Replace spring.</p> <p>Step 2. Check for cracked or dented retaining plate (4). Replace retaining plate.</p> <p>Step 3. Check for cracked or worn detent (8). Replace detent.</p> <p>3. M234 LAUNCHER IS LOOSE ON RIFLE BARREL.</p> <p>Step 1. Check for cracked or bent lock-release lever (9). Replace lock-release lever.</p> <p>Step 2. Check for improperly seated or cracked lock-release pin (10). Replace lock-release pin.</p> <p>Step 3. Check for cracks or crossed threads on lock-release sleeve (11). Replace lock-release sleeve.</p>	 <p>The diagrams illustrate the locations of various components: Part 4 is the retaining plate; Part 7 is the detent spring; Part 8 is the detent; Part 9 is the lock-release lever; Part 10 is the lock-release pin; and Part 11 is the lock-release sleeve. The diagrams show exploded views and views of the launcher mounted on a rifle barrel.</p>

4. PROJECTILE FLIGHT IS ERRATIC.

Step 1. Check for wear to the edge of the center rivet head, loose or broken keys (6), or bent or dented launching cup (3).

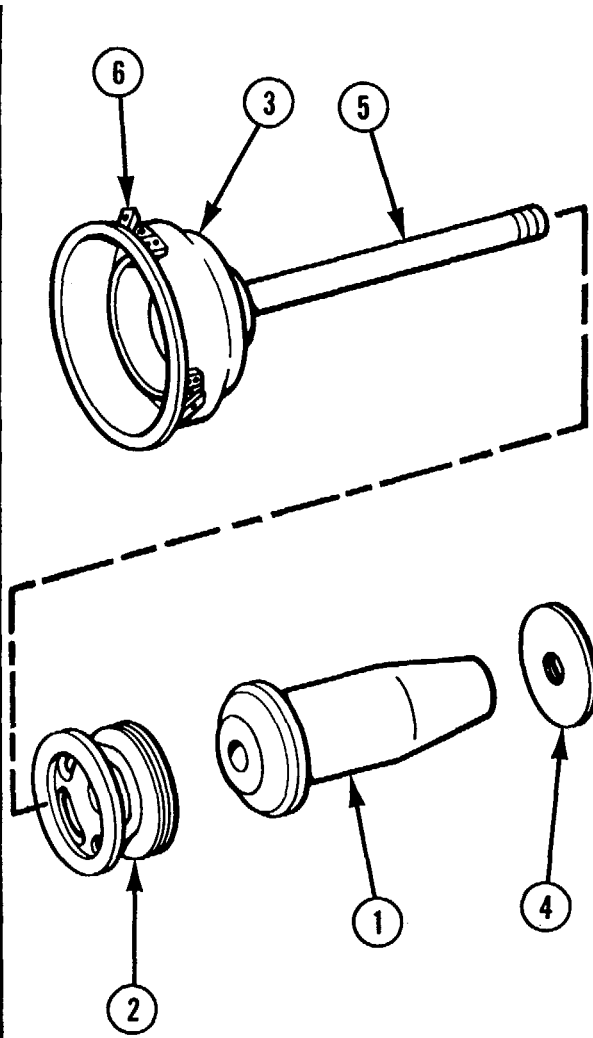
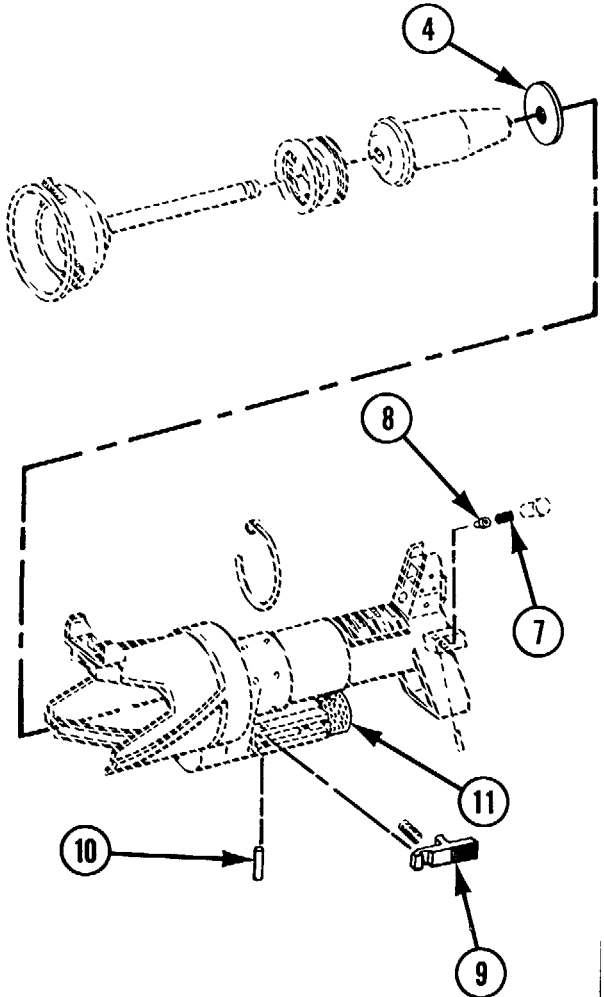
Replace launching cup.

Step 2. Check for cracked or chipped grooves (12) in launcher body (13).

Replace entire launcher.

5. MANIFOLD RETAINING PIN IS DIFFICULT TO REMOVE OR INSTALL.

Step 1. Check for missing handle or kinked manifold retaining pin (14).

Replace manifold retaining pin.

Step 2. Check groove in manifold (2) for cracks or chipped edges.

Replace manifold.

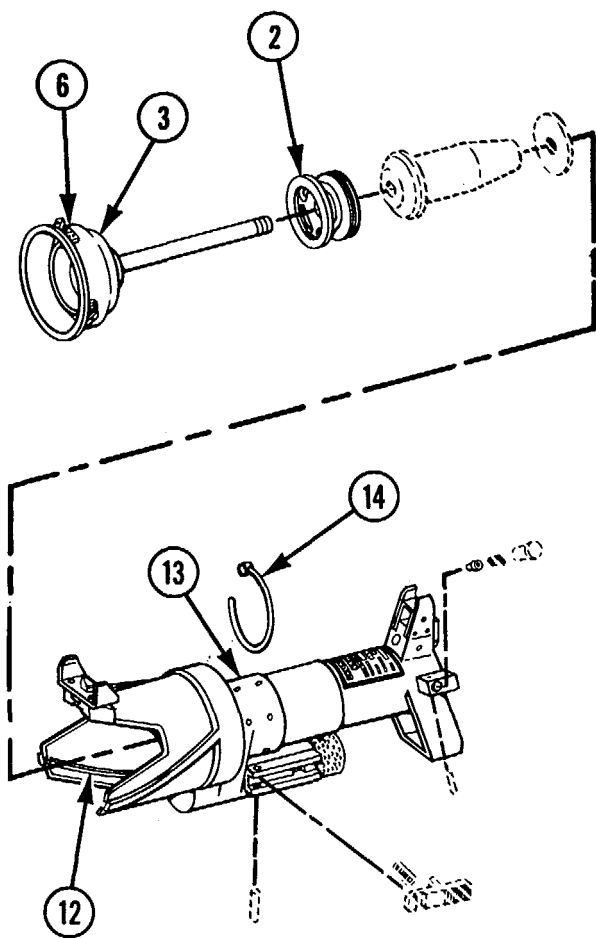

Section V. MAINTENANCE PROCEDURES

12-9. INTRODUCTION

The following procedures are for organizational personnel. Paragraph 2-10 is a summary procedure.

Detailed procedures begin in paragraph 2-11.

2-10. M234 LAUNCHER-SUMMARY PROCEDURE

INITIAL SETUP	
Tools Small arms repairman tool kit (SC 4933-95-CL-A07)	Personnel Required Armorer/unit supply specialist MOS 76Y
Materials/Parts RBC (item 1, app D) Cloth (item 2, app D) LSA (item 3, app D) Sealing compound (item 4, app D) Soap (item 5, app D)	Troubleshooting References See paragraph 2-8 References TM 9-1010-224-10 TM 9-1005-249-10

List of Tasks

Task No.	Task	Task Ref (Page)	Troubleshooting Ref No. (Para)
	Maintain M234 launcher: <p style="text-align: center;">NOTE Disassemble only as required to perform PMCS, correct malfunctions, or replace damaged parts.</p> a. Disassemble. b. Clean. c. Inspect. d. Repair. e. Lubricate. f. Reassemble.	 2-11 2-15 2-18 2-18 2-18 2-19	 2-8

2-11. M234 LAUNCHER-MAINTENANCE INSTRUCTIONS

THIS TASK COVERS:

- a. Disassembly
- b. Cleaning
- c. Inspection
- d. Repair
- e. Lubrication
- f. Reassembly

NOTE

Disassemble only as required to perform PMCS, correct malfunctions, or replace damaged parts.

INITIAL SETUP

Tools

Small arms repairman tool kit (SC 4933-95-CL-A07)

Personnel Required

Armorer/unit supply specialist MOS 76Y

Materials/Parts

- RBC (item 1, app D)
- Cloth (item 2, app D)
- LSA (item 3, app D)
- Sealing compound (item 4, app D)
- Soap (item 5, app D)

Troubleshooting References

See paragraph 2-8

References

- TM 9-1010-224-10
- TM 9-1005-249-10

DISASSEMBLY

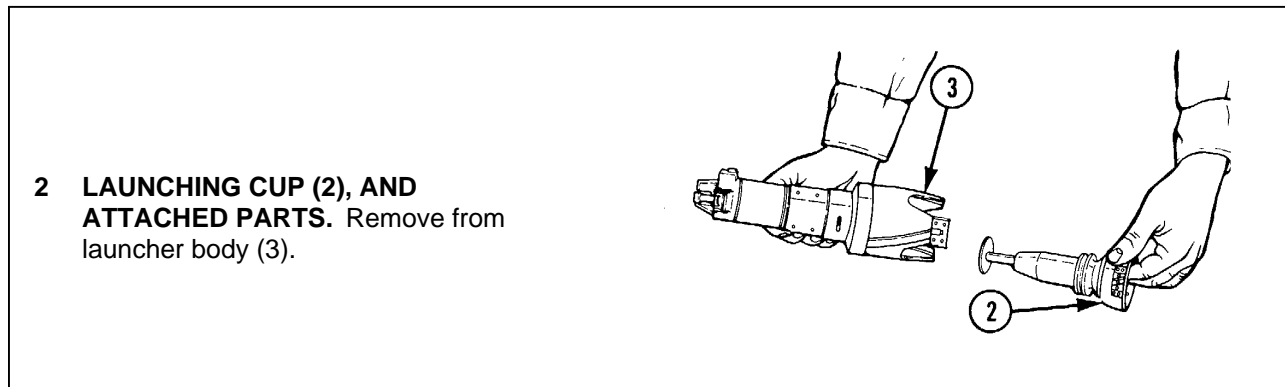
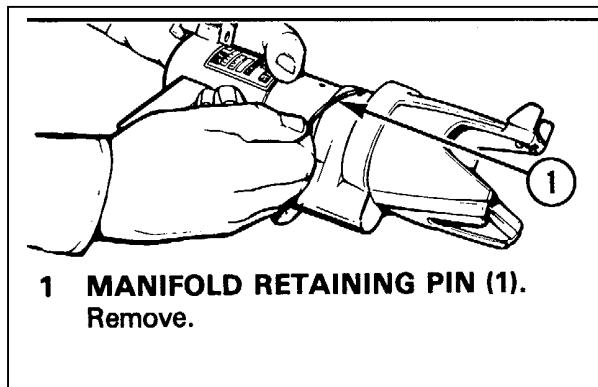

2-11. M234 LAUNCHER-MAINTENANCE INSTRUCTIONS (cont)

DISASSEMBLY (cont)

3 **RETAINING PLATE (4).** Unscrew and remove from shaft (5).

4 **BUFFER (6) AND MANIFOLD (7).** Remove from shaft (5).

5 **DETENT SPRING PIN (8).** Remove using drive pin punch (9) and hammer (10).

6 **RETAINER (11), CYLINDRICAL SPRING (12) AND DETENT (13).** Remove.

7 **STOP SCREW (14) AND WASHER (15).** Remove, using cross tip screwdriver (16).

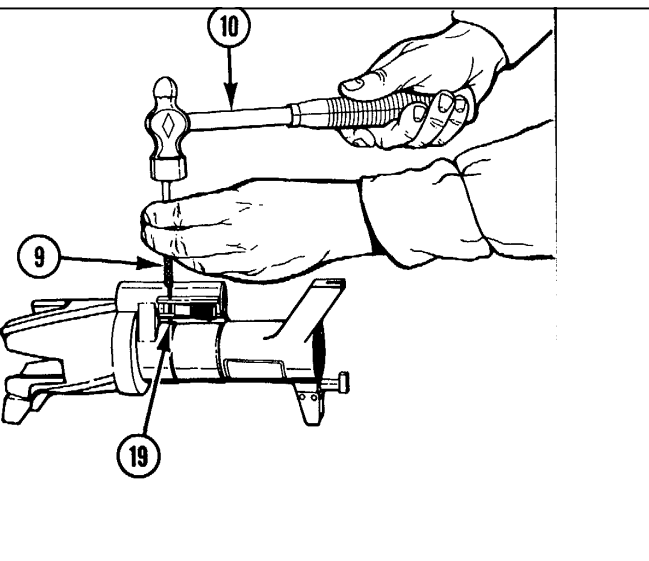
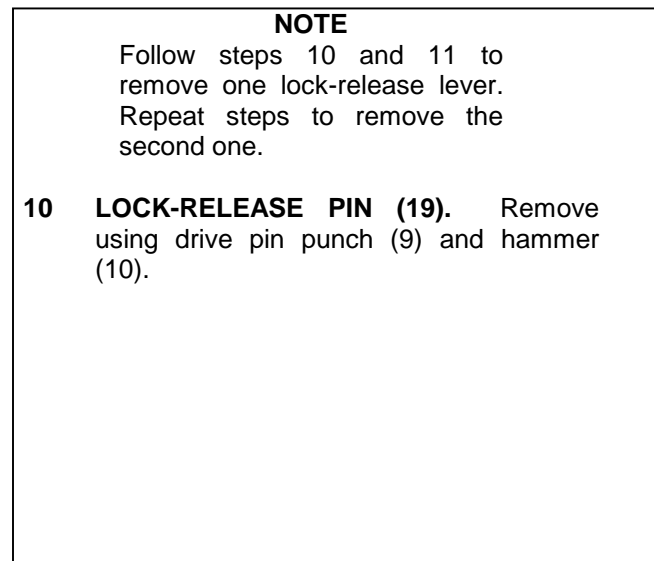
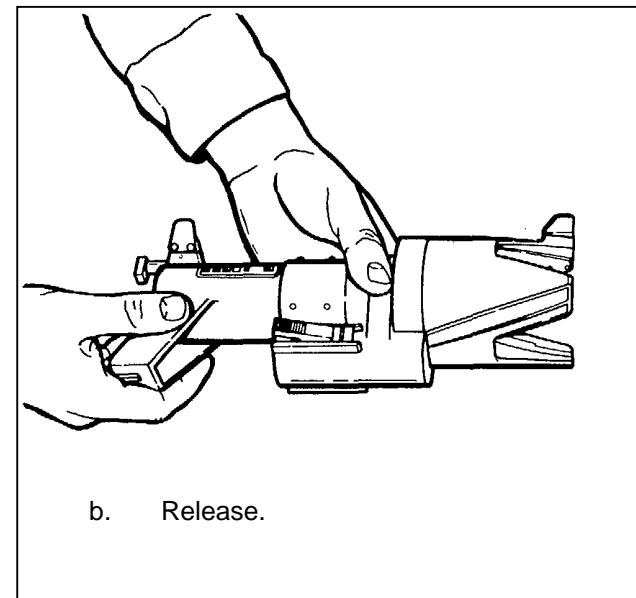
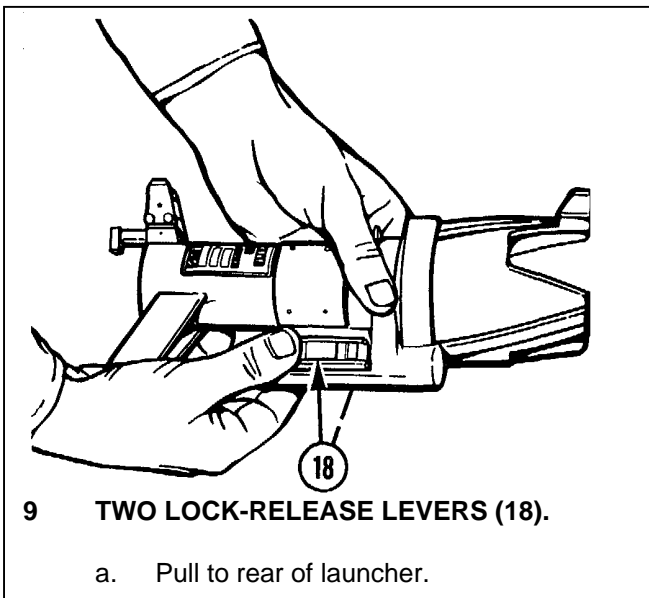
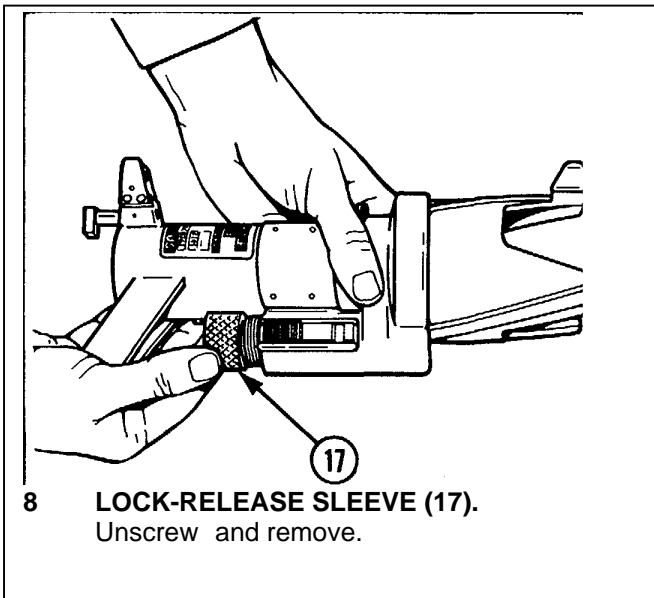

2-11. M234 LAUNCHER-MAINTENANCE INSTRUCTIONS (cont)

DISASSEMBLY (cont)

12 RETAINING RING (21).

- a. Place blade of flat tip screwdriver (22) in wedge (23) on end of retaining ring (21).

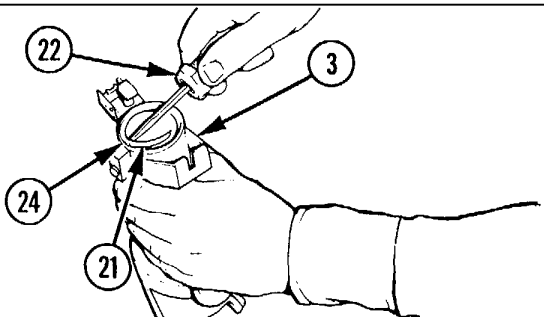
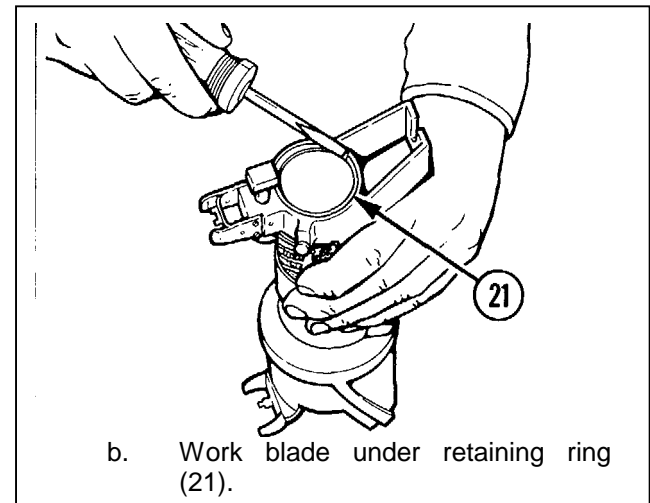
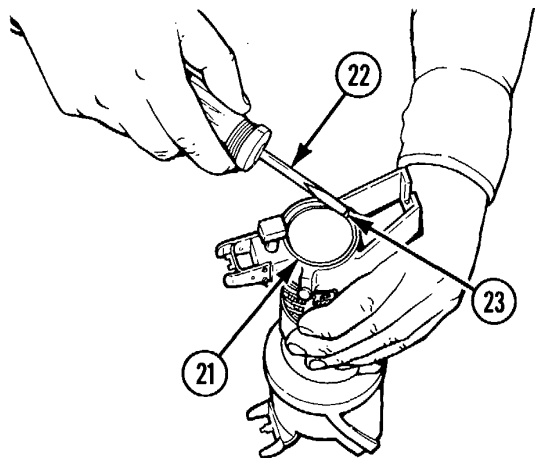

- c. Push screwdriver (22) under retaining ring (21) and around retaining ring groove (24) in launcher body (3).

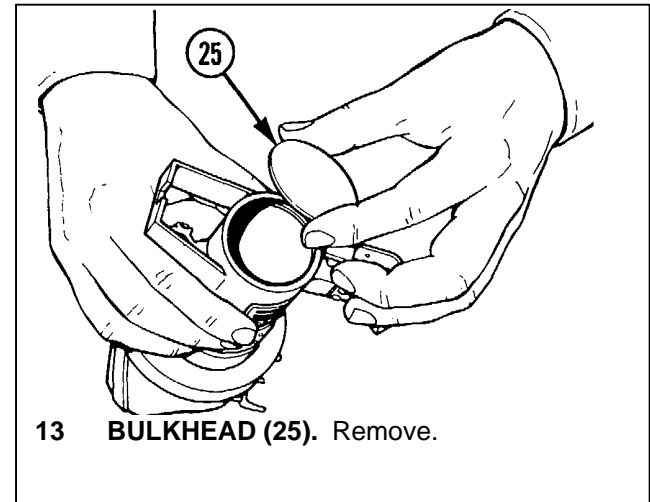
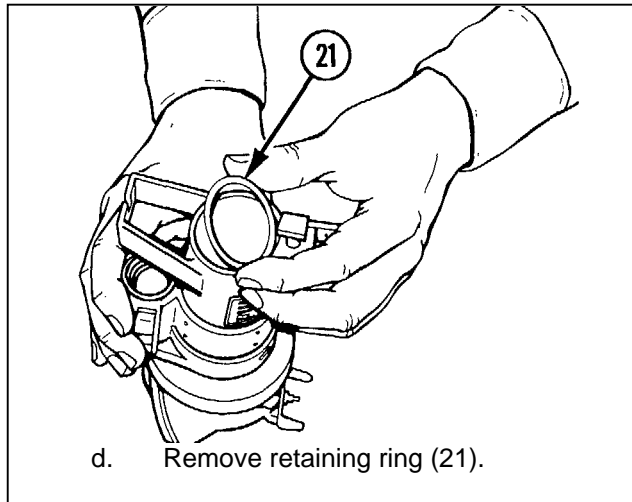

CLEANING

CAUTION

Do not allow rifle bore cleaner to come in contact with the buffer as damage may result.

- 1 **BUFFER (6).** CLEAN with soap (item 5, app D) and water. Remove burnt powder with dry lint-free cloth (item 2, app D).

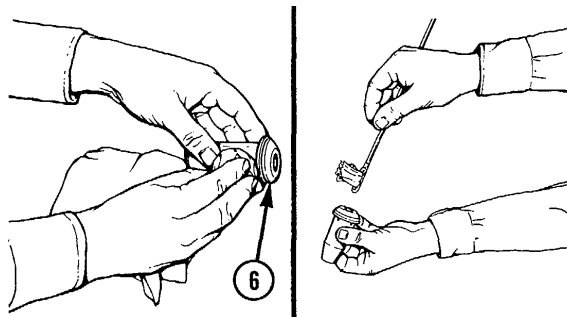

The diagram shows a hand holding a manifold (7) and another hand using a brush to clean its internal components.

- 2 **MANIFOLD (7).** CLEAN with RBC (item 1, app D), bore brush, and small arms cleaning (tooth) brush. Wipe dry with lint-free cloth (item 2, app D).

- 3 **LAUNCHING CUP (2).**
 - a. CLEAN shaft using RBC (item 1, app D) and bore brush.
 - b. CLEAN inside of launching cup using RBC (item 1, app D) on lint free cloth (item 2, app D).

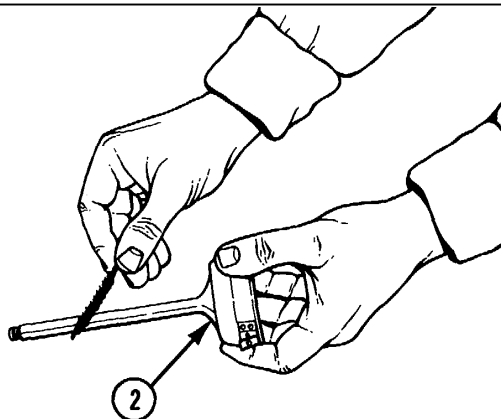

The diagram shows a hand holding a key and another hand using a brush to clean its surface.

- c. CLEAN keys using RBC (item 1, app D) and small arms cleaning (tooth) brush.

2-11. M234 LAUNCHER-MAINTENANCE INSTRUCTIONS (cont)

CLEANING (cont)

3 LAUNCHING CUP (2). (cont)

- d. Use end of manifold retaining pin to remove burnt powder or foreign matter from side of keys. Wipe all parts dry with lint-free cloth (item 2, app D).

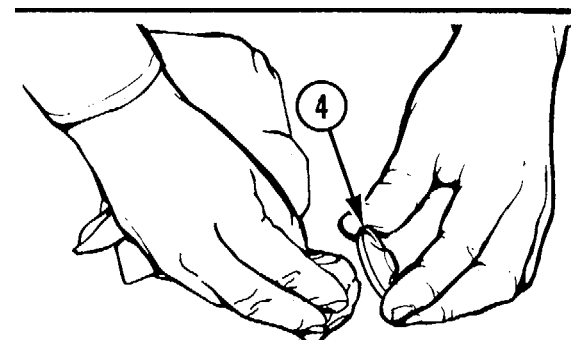
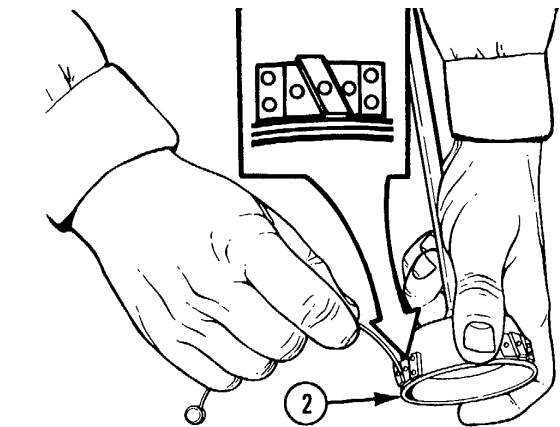

- 4 **RETAINING PLATE (4).** CLEAN using RBC (item 1, app D) and lint-free cloth (item 2, app D). Wipe dry with lint-free cloth (item 2, app D).

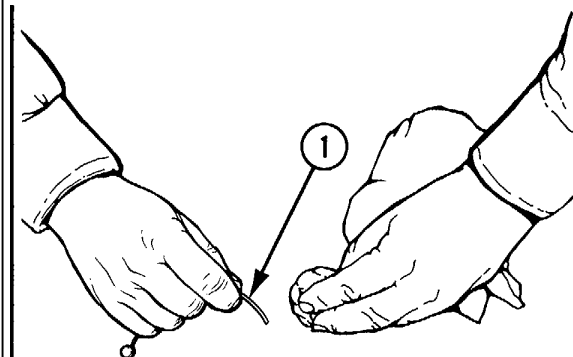

- 5 **MANIFOLD RETAINING PIN (1).** CLEAN with dry lint-free cloth (item 2, app D).

- 6 **LOCK-RELEASE LEVERS (18), LOCK RELEASE SPRINGS (20), AND LOCK-RELEASE SLEEVE (17).** CLEAN with RBC (item 1, app D) and small arms cleaning (tooth) brush. Wipe dry with lint-free cloth (item 2, app D).

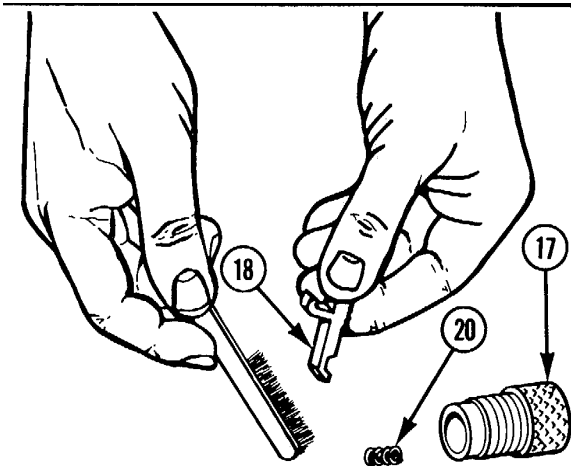

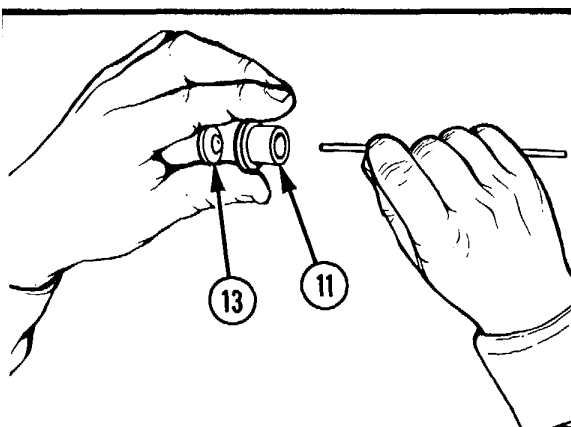

7 DETENT (13) AND RETAINER (11).
 CLEAN with RBC (item 1, app D) and pipe cleaner. (Pipe cleaners are listed in TM 9-1005-249-10.)

8 BULKHEAD (25) AND RETAINING RING (21). CLEAN using RBC (item 1, app D) and lint-free cloth (item 2, app D). Wipe dry with lint-free cloth (item 2, app D).

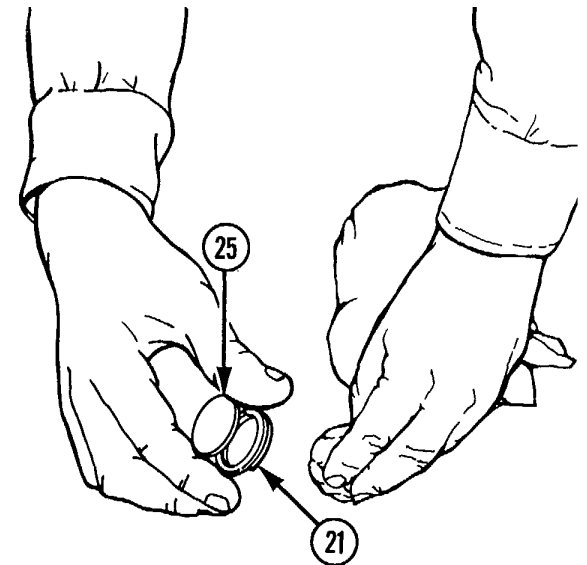

9 M234 LAUNCHER BODY (3).

a. CLEAN inside as far back as manifold retaining pin groove using RBC (item 1, app D) and small arms cleaning (tooth) brush.

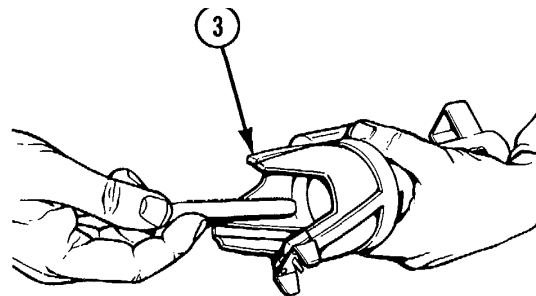

b. CLEAN grooves using RBC (item 1, app D) and bore brush. Wipe dry with lint-free cloth (item 2, app D).

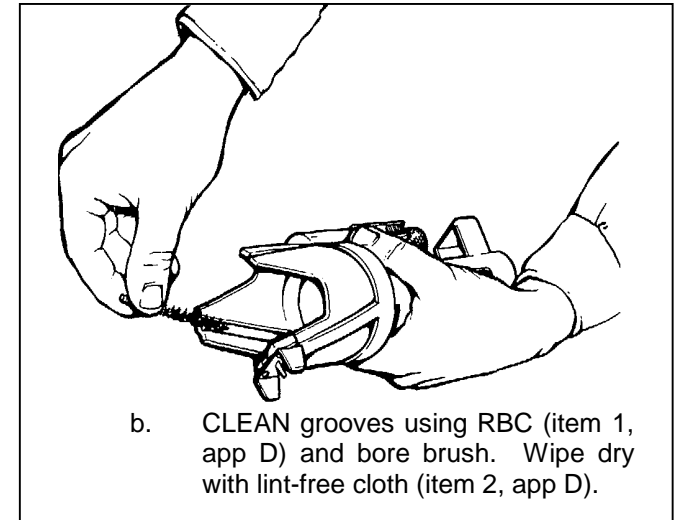

2-11. M234 LAUNCHER-MAINTENANCE INSTRUCTIONS (cont)

CLEANING (cont)

9 M234 LAUNCHER BODY (3). (cont)

c. CLEAN groove, if lock-release levers have been removed, with RBC (item 1, app D) and small arms cleaning (tooth) brush.

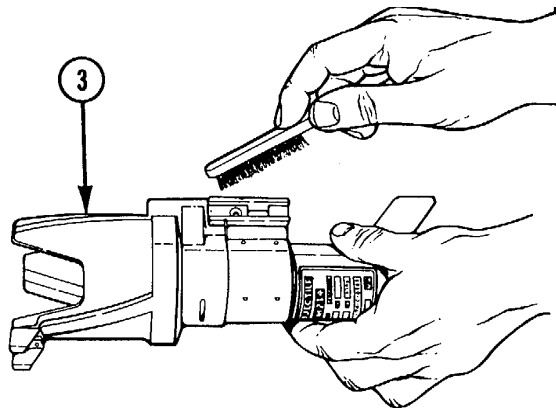

INSPECTION

Inspect in accordance with instructions in preventive maintenance checks and services (PMCS) (para 2-6).

REPAIR

Repair of the M234 launcher is accomplished by the replacement of damaged parts (app C).

LUBRICATION

CAUTION
Do not allow LSA to contact buffer (6). LSA will destroy the rubber and cause equipment malfunction.

NOTE
Do not lubricate inside launcher body rearward of the grooves.

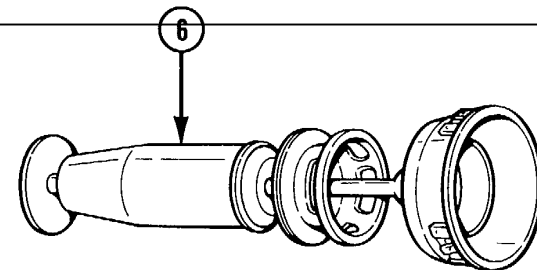

Lightly lubricate the following parts with LSA (item 3, app D):

- Inside launcher body and grooves (26)
- Manifold retaining pin (1)
- Manifold groove (27)
- Lock-release levers (18)
- Lock-release sleeve threads (28)
- Inside retainer (11)

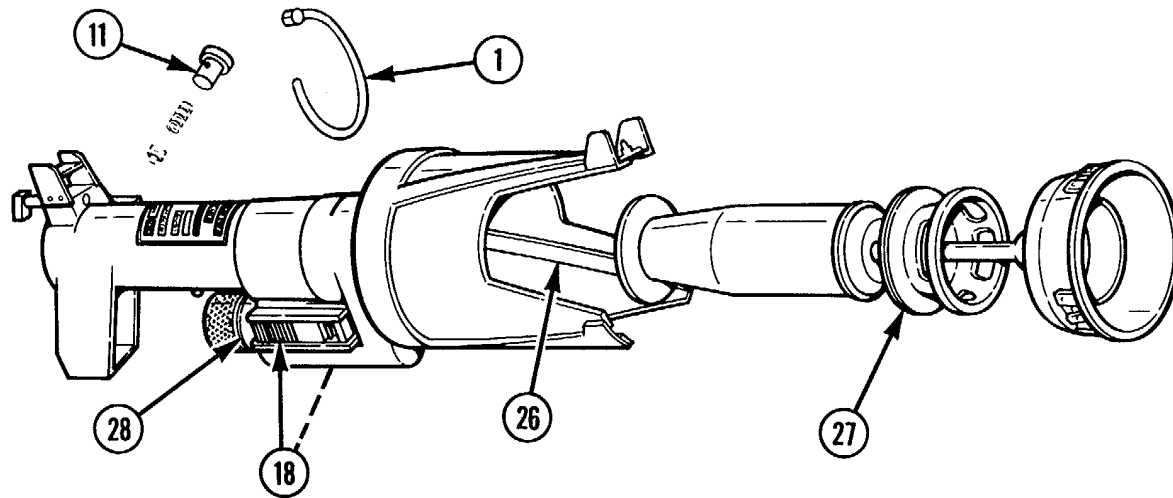

REASSEMBLY

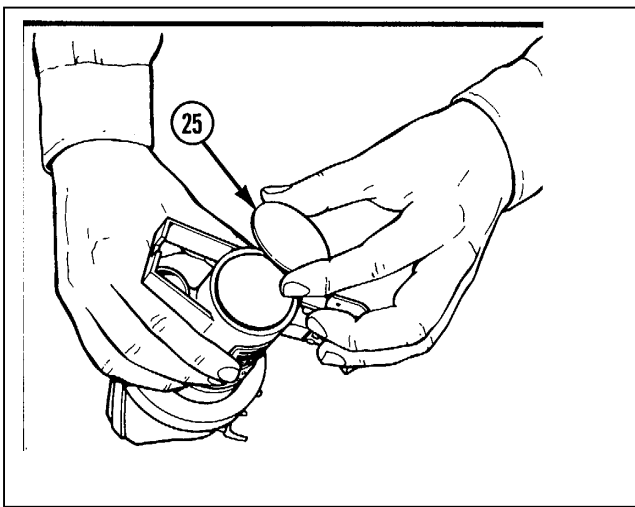

2 RETAINING RING (21).

- a. Spread apart with fingers and position over end of launcher body (3).

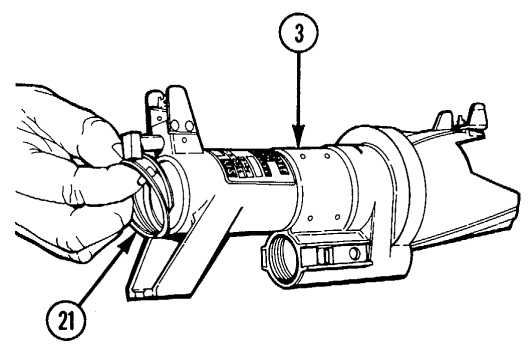

2-11. M234 LAUNCHER-MAINTENANCE INSTRUCTIONS (cont)

REASSEMBLY (cont)

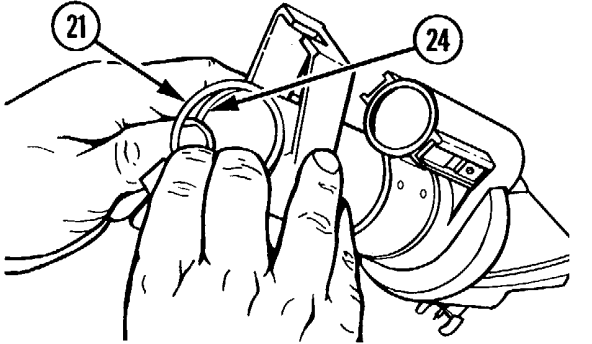

2 RETAINING RING (21). (cont)

b. Insert end into ring groove (24) in launcher body.

NOTE

Follow steps 3 thru 5 for installing one lock-release lever. Repeat for the second one.

c. Exert downward pressure and move fingers counterclockwise along retaining ring (21) until it is completely inserted in groove (24).

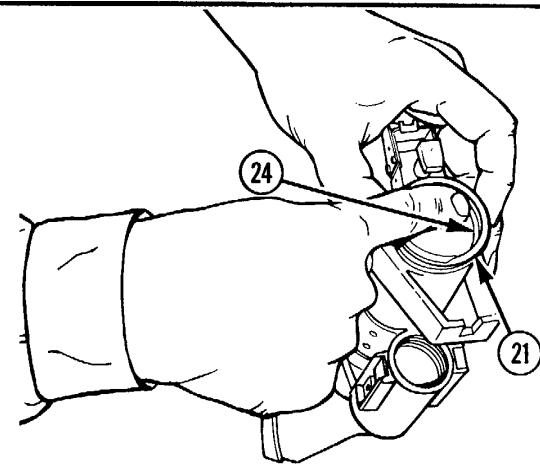

3 LOCK-RELEASE SPRING (20). Install in launcher body (3).

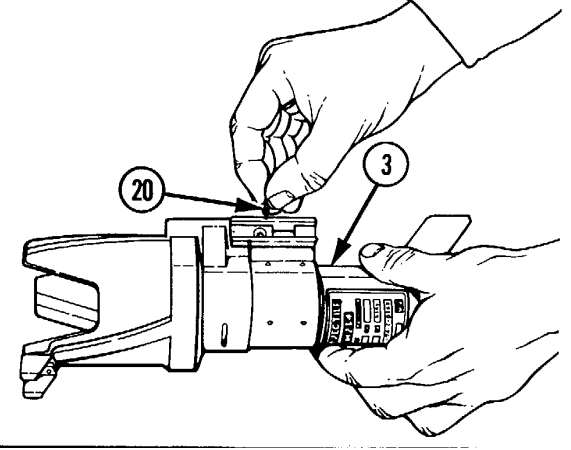

- 4 **LOCK-RELEASE LEVER (18).** Position over lock-release spring (20) and install in launcher body (3).

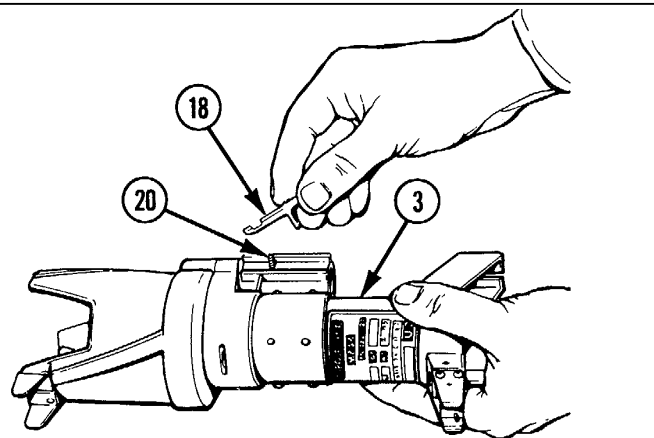

- 5 **LOCK-RELEASE PIN (19).** Install, using hammer (10).

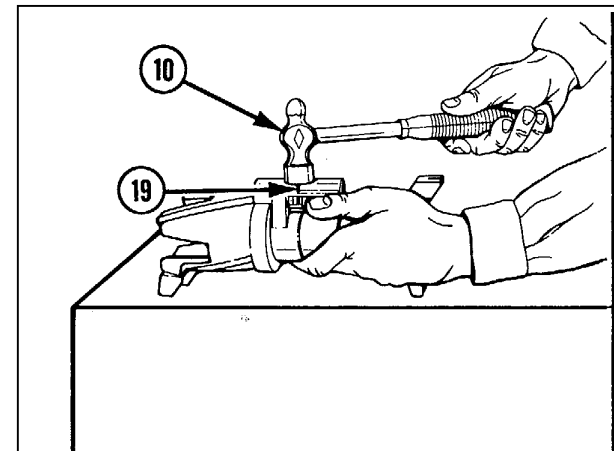

NOTE

When installing and tightening the lock-release sleeve, ensure lock-release levers (18) are held to the body of the launcher.

- 6 **LOCK-RELEASE SLEEVE (17).** Screw into launcher body (3).

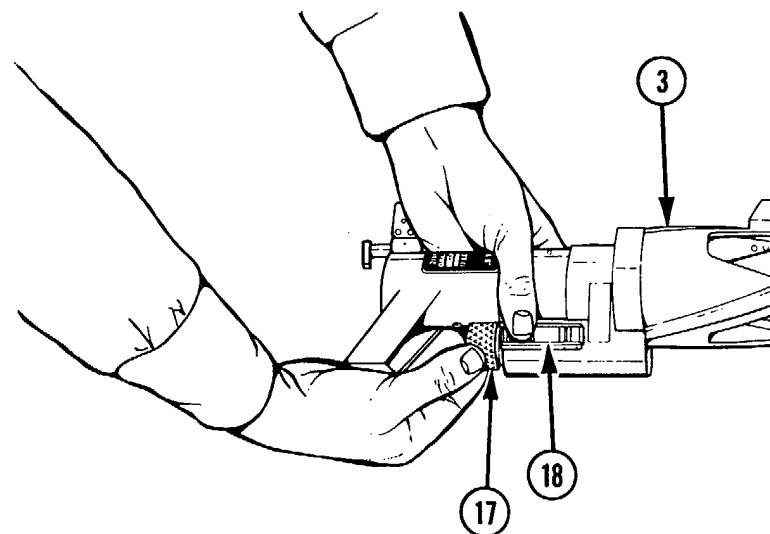

2-11. M234 LAUNCHER-MAINTENANCE INSTRUCTIONS (cont)

REASSEMBLY (cont)

7 WASHER (15) AND STOP SCREW (14). Apply sealing compound (item 4, app D) to threads and install, using cross tip screwdriver (16).

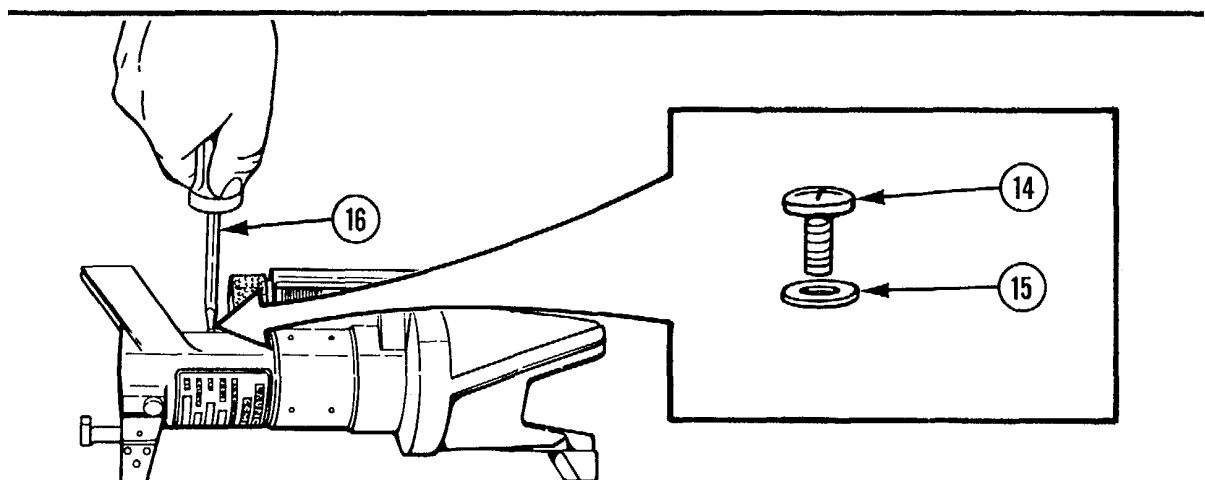

NOTE
Install detent (13) with flat side out.

8 DETENT (13), CYLINDRICAL SPRING (12), AND RETAINER (11).

a. Install.

b. Aline hole in retainer (11) with hole in launcher body (3).

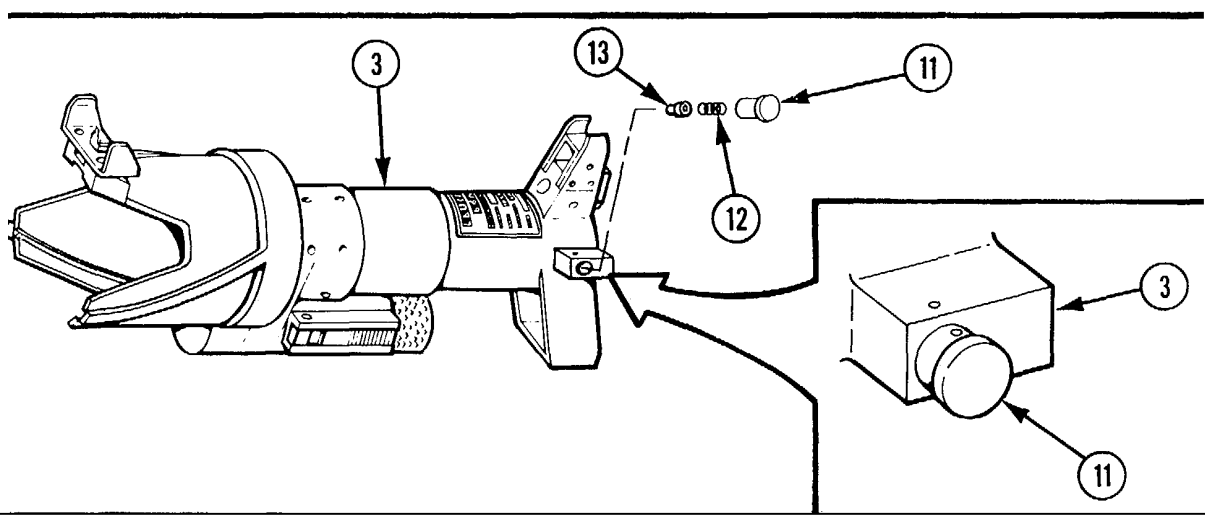

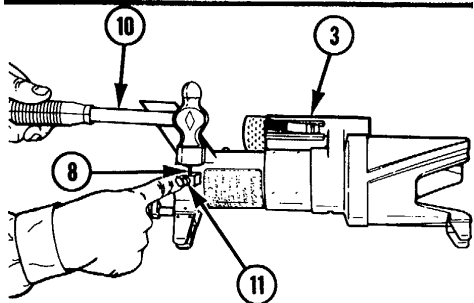

9 DETENT SPRING PIN (8). Install in hole in launcher body (3) and through hole in retainer (11) using hammer (10).

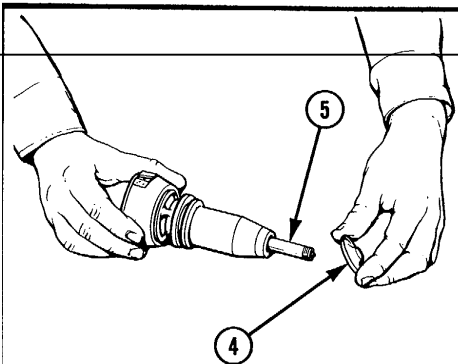

11 RETAINING PLATE (4). Screw onto shaft (5) and fingertighten.

NOTE

When installing the manifold (7), be sure that the large end goes next to the launching cup (2).

10 MANIFOLD (7) AND BUFFER (6). Install on launching cup (2).

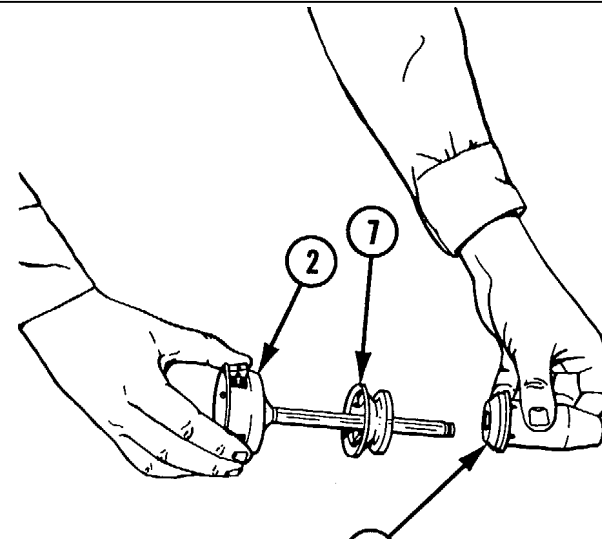

NOTE

Ensure keys (29) on launching cup (2) are aligned with and slide into launcher body grooves (26).

12 LAUNCHING CUP (2) AND ATTACHED PARTS. Install in launcher body (3).

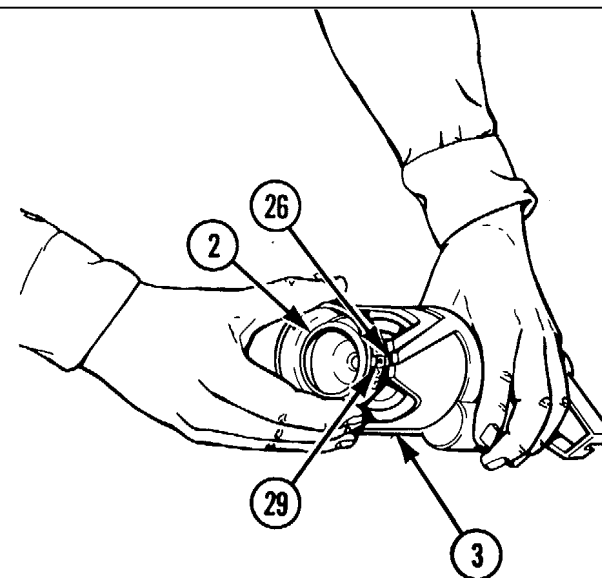

2-11. M234 LAUNCHER-MAINTENANCE INSTRUCTIONS (cont)

REASSEMBLY (cont)

WARNING

Aline manifold groove with slot in top of launcher body. The manifold retaining pin will then fit in groove and will keep launching cup and attached parts from being expelled when launcher is fired. Failure to comply could cause injury to personnel.

NOTE

Take care when installing the manifold retaining pin to avoid bending or breaking.

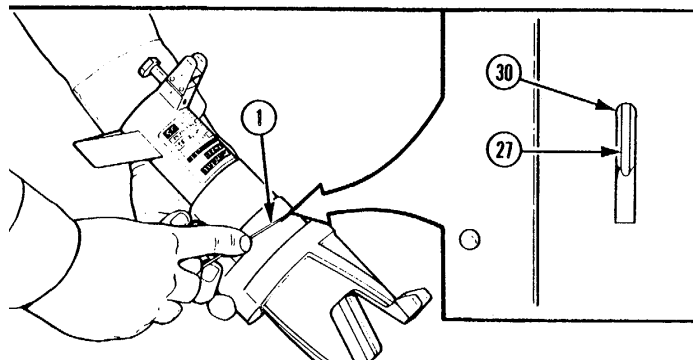

- 13 MANIFOLD GROOVE (27).** Aline with the center of the manifold retaining pin hole (30) and install manifold retaining pin (1).

The diagram shows a hand pulling a launching cup (2) forward on the launcher body to ensure it is properly seated.

14 LAUNCHING CUP (2). Pull forward to ensure manifold is properly seated.

15 M234 LAUNCHER (31). Clean exterior surface with lint-free cloth (item 2, app D) and small arms cleaning (tooth) brush.

The diagram shows a hand using a brush to clean the exterior surface of the M234 launcher (31).

Section VI. PREPARATION FOR STORAGE OR SHIPMENT

2-12. PREPARATION FOR STORAGE OR SHIPMENT

- a.* Security of the M234 launcher will be maintained in accordance with AR 190-11, chapter 2.
- b.* The launcher will be cleaned and lightly lubricated as specified in the maintenance section. The launcher will be repackaged using the foam cushion and wooden box in which launcher was received.
- c.* The launcher will meet long term storage.

**APPENDIX A
REFERENCES**

A-1. TECHNICAL MANUALS

TM 9-1010-224-10.....	Operator's Manual, Launcher, Projectile, 64 Millimeter: Riot Control, M234.	CTA 50-970	Expendable Items (Except Medical, Class V, Repair Parts, and Heraldic Items).
TM 9-1005-249-10	Operator's Manual: M16A1 Rifle.	DA Form 285	Accident Report.
TM 750-2447	Procedures for Destruction of Equipment in Federal Supply Classifications 1000, 1005, 1010, 1015, 1020, 1025, 1030, 1055, 1090, and 1095, To Prevent Enemy Use.	DA Form 2028	Recommended Changes to Publications and Blank Forms.
		DA Form 2028-2	Recommended Changes to Equipment Technical Manuals.
		DA PAM 738-750	Maintenance Management Update.

A-2. OTHER

AR 75-1	Malfunctions Involving Ammunition and Explosives, Report Control Symbol AMC-132 (MIN).	SF Form 364	Report of Discrepancy (ROD)
AR 190-11	Physical Security of Weapons, Ammunition, and Explosives.	FM 21-11	First Aid for Soldiers.
AR 385-40	Accident Reporting and Records.	SB 708-42	Federal Supply Code for Manufacturers: United States and Canada-Code to Name (Cataloging Handbook H4-2).
CTA 8-100	Army Medical Department Expendable/Durable Items.	SF 368	Quality Deficiency Report.

**APPENDIX B
MAINTENANCE ALLOCATION CHART**

Section I. INTRODUCTION

B-1. GENERAL

- a.** This section provides a general explanation of all maintenance and repair functions authorized at various maintenance categories.
- b.** The Maintenance Allocation Chart (MAC) in Section II designates overall responsibility for the performance of maintenance functions on the identified end item or component. The implementation of the maintenance functions upon the end item or component will be consistent with the assigned maintenance functions.
- c.** Section III lists the common tool sets (not individual common tools) and special tools and test equipment required -for each maintenance function as referenced from Section II.
- d.** Section IV contains supplemental instructions and explanatory notes for a particular maintenance function as keyed from the MAC, Section II.

B-2. MAINTENANCE FUNCTIONS

Maintenance functions will be limited to and defined as follows:

- a. *Inspect.*** To determine the serviceability of an item by comparing its physical, mechanical, and/or electrical characteristics with established standards through examination.
- b. *Test.*** To verify serviceability by measuring the mechanical or electrical characteristics of an item and comparing those characteristics with prescribed standards.
- c. *Service.*** Operations required periodically to keep an item in proper operating condition, i.e., to clean (includes decontaminate, when required), to preserve, to drain, to paint, or to replenish fuel, lubricants, chemical fluids, or gases.
- d. *Adjust.*** To maintain, within prescribed limits, by bringing into proper or exact position, or by setting the operating characteristics to specified parameters.
- e. *Aline.*** To adjust specified variable elements of an item to bring about optimum or desired performance.

B-2. MAINTENANCE FUNCTIONS (cont)

- f. Calibrate.** To determine and cause corrections to be made or to be adjusted on instruments or test, measuring, and diagnostic equipments used in precision measurement. Consists of comparisons of two instruments, one of which is a certified standard of known accuracy, to detect and adjust any discrepancy in the accuracy of the instrument being compared.
- g. Install.** The act of emplacing, seating, or fixing into position an item, part, or module (component or assembly) in a manner to allow the proper functioning of an equipment or system.
- h. Replace.** The act of substituting a serviceable like type part, subassembly, or module (component or assembly) for an unserviceable counterpart.
- i. Repair.** The application of maintenance services¹ or other maintenance actions² to restore serviceability to an item by correcting specific damage, fault, malfunction, or failure in a part, subassembly, module (component or assembly), end item, or system.
- j. Overhaul.** That maintenance effort (service/action) necessary to restore an item to a completely serviceable/operational condition as prescribed by maintenance standards in appropriate technical

¹Services-inspect, test, service, adjust, align, calibrate, or replace.

²Actions--welding, grinding, riveting, straightening, facing, remachining, or resurfacing.

publications (i.e., DMWR). Overhaul is normally the highest degree of maintenance performed by the Army. Overhaul does not normally return an item to like new condition.

- k. Rebuild.** Consists of those services/actions necessary for the restoration of unserviceable equipment to a like new condition in accordance with original manufacturing standards. Rebuild is the highest degree of materiel maintenance applied to Army equipment. The rebuild operation includes the act of returning to zero those age measurements (hours/miles, etc) considered in classifying Army equipments/components.

B-3. EXPLANATION OF COLUMNS IN THE MAC, SECTION II

a. Column 1, Group Number. Column 1 lists functional group code numbers, the purpose of which is to identify components, assemblies, subassemblies, and modules with the next higher assembly.

b. Column 2, Component/Assembly. Column 2 contains the names of components, assemblies, subassemblies, and modules for which maintenance is authorized.

c. The launcher will meet long term storage. Column 3 lists the functions to be performed on the item listed in Column 2. (For detailed explanation of these functions, see para B-2.)

d. Column 4, Maintenance Category. Column 4 specifies, by the listing of a work time figure in the appropriate subcolumn(s), the category of maintenance authorized to perform the function listed in Column 3. This figure represents the active time required to perform the maintenance function at the indicated category of maintenance. If the number or complexity of the tasks within the listed maintenance function vary at different maintenance categories, appropriate work time figures will be shown for each category. The work time figure represents the average time required to restore an item (assembly, subassembly, component, module, end item, or system) to a serviceable condition under typical field operating conditions. This time includes preparation time, troubleshooting time, and quality assurance/quality control time in addition to the time required to perform the specific tasks identified for the maintenance functions authorized in the maintenance allocation chart. The symbol designations for the various maintenance categories are as follows:

- C Operator or crew.
- O Organizational maintenance.
- F Direct support maintenance.
- H General support maintenance.
- D Depot maintenance.

e. Column 5, Tools and Equipment. Column 5 specifies, by code, those common tool sets (not individual tools) and special tools, TMDE, and support equipment required to perform the designated function.

f. Column 6, Remarks. This column shall, when applicable, contain a letter code, in alphabetic order, which shall be keyed to the remarks contained in Section IV.

B-4. EXPLANATION OF COLUMNS IN TOOL AND TEST EQUIPMENT REQUIREMENTS, SECTION III

- a. Column 1, Reference Code.** The tool and test equipment reference code correlates with a code used in the MAC, Section II, Column 5.
- b. Column 2, Maintenance Category.** The lowest category of maintenance authorized to use the tool or test equipment.
- c. Column 3, Nomenclature.** Name or identification of the tool or test equipment.
- d. Column 4, National Stock Number.** The National stock number of the tool or test equipment.
- e. Column 5, Tool Number.** The manufacturer's part number.

B-5. EXPLANATION OF COLUMNS IN REMARKS, SECTION IV

- a. Column 1, Reference Code.** The code recorded in column 6, Section II.
- b. Column 2, Remarks.** This column lists information pertinent to the maintenance function being performed as indicated in the MAC, Section II.

Section II. MAINTENANCE ALLOCATION CHART FOR M234 LAUNCHER

(1) GROUP NUMBER	(2) COMPONENT/ ASSEMBLY	(3) MAINTENANCE FUNCTION	(4) MAINTENANCE CATEGORY					(5) TOOLS AND EQUIPMENT	(6) REMARKS
			C	O	F	H	D		
00	M234 Launcher	Inspect	0.1	0.1				1	
		Service	0.2	0.2					
		Repair	0.4	0.4					

Section III. TOOL AND TEST EQUIPMENT REQUIREMENTS FOR M234 LAUNCHER

TOOL OR TEST EQUIPMENT REF CODE	MAINTENANCE CATEGORY	NOMENCLATURE	NATIONAL/ NATO STOCK NUMBER	TOOL NUMBER
1	0	Tool Kit, Small Arms Repairman	4933-00-357-7770	SC 4933-95-CL-A07

Section IV. REMARKS

Reference Code	Remarks
	Not applicable

**APPENDIX C
REPAIR PARTS AND SPECIAL TOOLS LIST**

Section I. INTRODUCTION

C-1. SCOPE

This appendix lists spares and repair parts; special tools; special test, measurement, and diagnostic equipment (TMDE); and other special support equipment required for performance of organizational maintenance of the M234 launcher. It authorizes the requisitioning and issue of spares and repair parts as indicated by the source and maintenance codes.

C-2. GENERAL

This repair parts and special tools list is divided into the following sections:

- a. Section II. Repair Parts List.** A list of spares and repair parts authorized for use in the performance of maintenance. The list also includes parts which must be removed for replacement of the authorized parts. Parts lists are composed of functional groups in numeric sequence, with the parts in each group listed in figure and item number sequence.
- b. Section III. Special Tools List.** Not applicable.
- c. Section IV. National Stock Number and Part Number Index.** A list, in National item identification number (NIIN) sequence, of all National stock numbers (NSN) appearing in the listings, followed by a list in alphameric sequence of all part numbers appearing in the listings. National stock numbers and part numbers are cross-referenced to each illustration figure and item number appearance.

C-3. EXPLANATION OF COLUMNS

- a. Illustration.** This column is divided as follows:
 - (1) Figure Number.** Indicates the figure number of the illustration on which the item is shown.
 - (2) Item Number.** The number used to identify item called out in the illustration.
- b. Source, Maintenance, and Recoverability (SMR) Codes.**
 - (1) Source Code.** Source codes indicate the manner of acquiring support items for maintenance, repair, or overhaul of end items. Source codes are entered in the first and second positions of the uniform SMR code format as follows:

Code	Definition
PA.....	Item procured and stocked for anticipated or known usage.
XA.....	Item is not procured or stocked because the requirements for the item will result in the replacement of the next higher assembly.

C-3. EXPLANATION OF COLUMNS (cont)

NOTE

Cannibalization or salvage may be used as a source of supply for any items coded above except those coded XA.

(2) **Maintenance Code.** Maintenance codes are assigned to indicate the levels of maintenance authorized to USE and REPAIR support items. The maintenance codes are entered in the third and fourth positions of the uniform SMR code format as follows:

(a) The maintenance code entered in the third position will indicate the lowest maintenance level authorized to remove, replace, and use the support item. The maintenance code entered in the third position will indicate one of the following levels of maintenance:

Code	Application/Explanation
O.....	Support item is removed, replaced, used at the organizational level.

(b) The maintenance code entered in the fourth position indicates whether the item is to be repaired and identifies the lowest maintenance level with the capability to perform complete repair (i.e., all authorized maintenance functions). This position will contain one of the following maintenance codes:

Z.....Nonreparable. No repair is authorized.

(3) **Recoverability Code.** Recoverability codes are assigned to support items to indicate the disposition action on unserviceable items. The recoverability code is entered in the fifth position of the uniform SMR code format as follows:

Recoverability Codes

Definition

ZNonreparable item. When unserviceable, condemn and dispose at the level indicated in position 3.

c. **National Stock Number.** Indicates the National stock number assigned to the item and which will be used for requisitioning.

d. **Part Number.** Indicates the primary number used by the manufacturer (individual, company, firm, corporation, or Government activity), which controls the design and characteristics of the item by means of its engineering drawings, specifications, standards, and inspection requirements to identify an item or range of items.

NOTE

When a stock numbered item is requisitioned, the item received may have a different part number than the part being replaced.

- e. **Federal Supply Code for Manufacturers (FSCM).** The FSCM is a five-digit numeric code listed in SB 708-42 which is used to identify the manufacturer, distributor, or Government agency, etc.
- f. **Description.** Indicates the Federal item name and, if required, a minimum description to identify the item.
- g. **Unit of Measure(U/M).** Indicates the standard of the basic quantity of the listed item as used in performing the actual maintenance function. This measure is expressed by a two-character alphabetical abbreviation (e.g., ea, in., pr, etc). When the unit of measure differs from the unit of issue, the lowest unit of issue that will satisfy the required units of measure will be requisitioned.
- h. **Quantity Incorporated in Unit.** Indicates the quantity of the item used in the breakout shown on the illustration figure, which is prepared for functional group, subfunctional group, or an assembly. A "V" appearing in this column in lieu of quantity indicates that no specific quantity is applicable (e.g., shims, spacers, etc).

C-4. SPECIAL INFORMATION

Not applicable.

C-5. HOW TO LOCATE REPAIR PARTS

- a. **When National Stock Number or Part Number Is Unknown:**

- (1) **First.** Using the table of contents, determine the functional group within which the item belongs. This is necessary since illustrations are prepared for functional groups, and listings are divided into the same groups.
- (2) **Second.** Find the illustration covering the functional group to which the item belongs.
- (3) **Third.** Identify the item on the illustration and note the illustration figure and item number of the item.
- (4) **Fourth.** Using the repair parts list, find the figure and item number noted on the illustration.

- b. **When National Stock Number or Part Number Is Known:**

- (1) First. Using the index of National stock numbers and part numbers, find the pertinent National stock number or part number. This index is in NIIN sequence followed by a list of part numbers in alphameric sequence, cross-referenced to the illustration figure number and item number.
- (2) Second. After finding the figure and item number, locate the figure and item number in the repair parts list.

C-6. ABBREVIATIONS

Not applicable.

Section II. REPAIR PARTS LIST

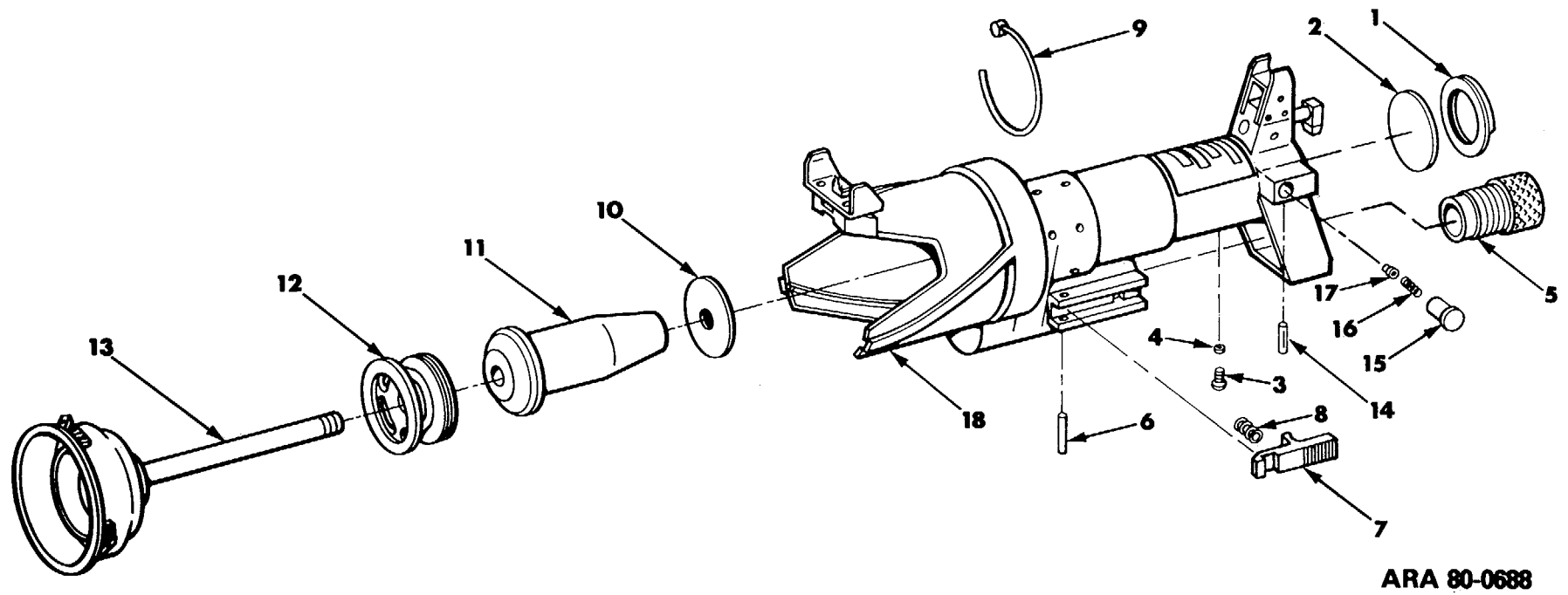

Figure C-1. Launcher, projectile, 64 millimeter: riot control, M234.

(1) ILLUSTRATION		(2)	(3)	(4)	(5)	(6)	(7)	(8)
(a) FIG. NO.	(b) ITEM NO.	SMR CODE	NATIONAL STOCK NUMBER	PART NUMBER	FSCM	DESCRIPTION USABLE ON CODE	U/M	QTY INC IN UNIT
C-1	1	PAOZZ	5365-01-114-3210	M27426-4126D	81349	GROUP OO LAUNCHER, PROJECTILE, 64 MILLIMETER: RIOT CONTROL, M234, D122-3-30 RING, RETAINING	EA	1
C-1	2	PAOZZ	1010-01-063-0086	122-3-44	81361	BULKHEAD.....	EA	1
C-1	3	PAOZZ	5305-00-054-5644	MS51957-11	96906	SCREW, MACHINE	EA	1
C-1	4	PAOZZ	5310-00-660-3372	NAS620A4L	80205	WASHER, FLAT	EA	1
C-1	5	PAOZZ	1010-01-046=8346	C122-3-39	81361	SLEEVE, LOCK-RELEASE.....	EA	1
C-1	6	PAOZZ	5315-00-664-7294	MS16562-196	96906	PIN, SPRING	EA	2
C-1	7	PAOZZ	1010-01-044-5885	C122-3-17	81361	LEVER, LOCK-RELEASE.....	EA	2
C-1	8	PAOZZ	5360-01-051-0554	MS24585-1013	96906	SPRING, HELICAL, COMPRESSION	EA	2
C-1	9	PAOZZ	1010-01-J046-8344	C122-3-78	81361	PIN, MANIFOLD RETAINING	EA	1
C-1	10	PAOZZ	1010-01-046-8345	C122-3-27	81361	PLATE, RETAINING, LAUNCHER CUP.....	EA	1
C-1	11	PAOZZ	1010-01-044-5884	C122-3-29	61361	BUFFER, RECOIL MECHANISM	EA	1
C-1	12	PAOZZ	1010-01-044-5882	C122-3-33	81361	MANIFOLD, PROJECTILE	EA	1
C-1	13	PAOZZ	1010-01-046-9399	D122-3-45	81361	CUP, PROJECTILE LAUNCHING	EA	1
C-1	14	PAOZZ	5315-00-844-5644	MS16562-194	96906	PIN, SPRING	EA	1
C-1	15	PAOZZ	1010-01-058-2999	122-3-132	81361	RET., HELICAL COMPRESSION SPRING	EA	1
C-1	16	PAOZZ	5360-01-065-8889	122-3-134	81361	SPRING, HELICAL COMPRESSION	EA	1
C-1	17	PAOZZ	1010-01-058-2989	122-3-133	81361	PLUNGER, DETENT	EA	1
C-1	18	XAOZZ	...	D122-3-31	81361	LAUNCHER BODY	EA	1

Section III. SPECIAL TOOLS LIST

(1) ILLUSTRATION		(2)	(3)	(4)	(5)	(6)	(7)	(8)
(a) FIG. NO.	(b) ITEM NO.	SMR CODE	NATIONAL STOCK NUMBER	PART NUMBER	FSCM	DESCRIPTION USABLE ON CODE	U/M	QTY INC IN UNIT
						Not applicable.		

Section IV. NATIONAL STOCK NUMBER AND PART NUMBER INDEX

STOCK NUMBER	FIGURE NO.	ITEM NO.	FIGURE FSCM	ITEM PART NUMBER	NO.	NO.
5305-00-0545644	C-1	3	81361	C122-3-17	C-1	7
5310-00-660-3372	C-1	4	81361	C122-3-27	C-1	10
5315-00-664-7294	C-1	6	81361	C122-3-29	C-1	11
5315-00844-5644	C-1	14	81361	C122-3-33	C-1	12
1010-01-044-5882	C-1	12	81361	C122-3-39	C-1	5
1010-01-044-5884	C-1	11	81361	C122-3-78	C-1	9
1010-01-044-5885	C-1	7	81361	D122-3-31	C-1	18
1010-01-046-8344	C-1	9	81361	D122-3-45	C-1	13
1010-01-046-8346	C-1	5	96906	MS16562-194	C-1	14
1010-01-046-9399	C-1	13	96906	MS16562-196	C-1	6
5360-01-051-0554	C-1	8	96906	MS24585-1013	C-1	8
1010-01-058-2989	C-1	17	96906	MS51957-11	C-1	3
1010-01-058-2989	C-1	17	80205	NAS620A4L	C-1	4
1010-01-063-0086	C-1	2	81361	122-3-132	C-1	15
5360-01-065-8889	C-1	16	81361	122-3-133	C-1	17
5365-01-114-3210	C-1	1	81361	122-3-44	C-1	2

APPENDIX D
EXPENDABLE/DURABLE SUPPLIES AND MATERIALS LIST

Section I. INTRODUCTION

D-1. SCOPE

This appendix lists expendable/durable supplies and materials you will need to operate and maintain the M234 launcher. This listing is for informational purposes only and is not authority to requisition the listed items. These items are authorized to you by CTA 50-970, Expendable/Durable Items (Except Medical, Class V, Repair Parts, and Heraldic Items), or CTA 8-100, Army Medical Department Expendable/Durable Items.

D-2. EXPLANATION OF COLUMNS

- a. **Column 1-Item Number.** This number is assigned to the entry in the listing and is referenced in the narrative instructions to identify the material (e.g., "Use cleaning compound, item 1, app D.").
- b. **Column 2-Level.** This column identifies the lowest level of maintenance that requires the listed item.

OOrganizational Maintenance

- c. **Column 3-National Stock Number.** This is the National stock number assigned to the item; use it to request or requisition the item.
- d. **Column 4-Description.** Indicates the Federal item name and, if required, a description to identify the item. The last line for each item indicates the part number followed by the Federal Supply Code for Manufacturer (FSCM) in parentheses, if applicable.
- e. **Column 5-Unit of Measure (U/M).** Indicates the measure used in performing the actual maintenance function. This measure is expressed by a two-character alphabetical abbreviation (e.g., ea, in., pr). If the unit of measure differs from the unit of issue, requisition the lowest unit of issue that will satisfy your requirements.

Section II. EXPENDABLE/DURABLE SUPPLIES AND MATERIALS LIST

(1) ITEM NUMBER	(2) LEVEL	(3) NATIONAL STOCK NUMBER	(4) DESCRIPTION	(5) U/M
1	C	6850-00-224-6663	CLEANING COMPOUND, RIFLE BORE: (RBC), 1-gal. (3.785-l) can MIL-C-372 (81349)	GL
2	C	8305-00-222-2423	CLOTH, CHEESECLOTH: cotton, 38- ½ in. (97.790 cm) w FED SPEC CCC-C-440, type 1, class 1 (81348)	YD
3	C	9150-00-753-4686	LUBRICATING OIL, SEMI-FLUID: automatic weapons (LSA), 1-gal. (3.785-l) can MIL-L-46000 (81349)	GL
4	C	8030-00-833-9116	SEALING COMPOUND: 50cc, grade HV MIL-S-22473 (81349)	CC
5	C	8520-00-228-0598	SOAP, TOILET: liquid, 1-gal. (3.785-l) container FED SPEC P-S-624, type 1 (81348)	GL

Change 1 D-2

ALPHABETICAL INDEX

Subject	Page
A	
Abbreviations, list of	1-2
Accidents, reporting.....	1-1
Arm	1-3
B	
Buffer:	
Cleaning.....	2-15
Installation.....	2-23
PMCS.....	2-5
Removal.....	2-12
Buffer housing	1-3
Bulkhead:	
Cleaning.....	2-17
Installation.....	2-19
PMCS.....	2-5
Removal.....	2-14
C	
Capabilities, equipment	1-3
Characteristics, equipment.....	1-3
Checking unpacked equipment.....	2-3
Cleaning	2-15
Common name.....	1-2

Subject	Page
Common tools and equipment	2-1
Components, location and description	1-3
Cross-reference list, nomenclature	1-2
Cylindrical spring:	
Installation.....	2-22
PMCS.....	2-4
Removal.....	2-12
D	
Data, equipment	1-3
Description of major components.....	1-3
Designations, official.....	1-2
Destruction of Army materiel to prevent enemy use	1-2
Detent:	
Cleaning.....	2-17
Installation.....	2-22
Location	1-3
PMCS.....	2-4
Removal.....	2-12
Detent spring pin:	
Installation.....	2-22
PMCS.....	2-4
Removal.....	2-12
Disassembly of M234 launcher	2-11

Subject	Page
EIR Reporting.....	1-2
Equipment characteristics, capabilities, and features	1-3
Equipment data	1-3
Equipment improvement recommendations (EIR)	1-2
Equipment purpose	1-1
Equipment, support	2-1
Errors, reporting	i
Expendable supplies and materials list:	
Introduction	D-1
List	D-2
F	
Features, equipment	1-3
First aid.....	inside front cover
Front sight.....	1-3
H	
How to use this manual	iii
I	
Improvement recommendations (EIR)	1-2

Subject	Page
Initial setup	2-10
Inspection	2-18
Installation (See individual part)	
L	
Launcher body:	
Cleaning.....	2-17
Description	1-3
PMCS.....	2-5
Service upon receipt	2-2
Launcher body grooves (cleaning)	2-17
Launcher, M234 (See M234 launcher)	
Launching cup:	
Cleaning.....	2-15
Installation.....	2-23
Location	1-3
PMCS.....	2-4
Removal.....	2-11
Service upon receipt	2-2
Troubleshooting	2-6
Launching cup keys (cleaning)	2-16
List of abbreviations.....	1-2
List of expendable supplies and materials	D-2
List of tasks	2-10
Location and description of major components.....	1-3

Subject	Page
L	
Lock release levers:	
Cleaning.....	2-16
Installation.....	2-21
Location	1-3
Lubrications.....	2-19
PMCS.....	2-5
Removal.....	2-13
Lock-release pins:	
Installation.....	2-21
PMCS.....	2-5
Removal.....	2-13
Lock release sleeve:	
Cleaning.....	2-16
Installation.....	2-21
Location	1-3
PMCS.....	2-5
Removal.....	2-13
Lock-release sleeve threads (lubrication).....	2-19
Lock-release springs:	
Cleaning.....	2-16
Installation.....	2-20
PMCS.....	2-5
Removal.....	2-13
Lubrication	2-18
M	
MAC (See maintenance allocation chart)	

Subject	Page
Maintenance allocation chart:	
Introduction	B-1
MAC for M234 launcher	B-4
Remarks	B-4
Tool and test equipment requirements for M234 launcher	B-4
Maintenance forms, records, and reports	1-1
Maintenance procedures, introduction	2-9
Maintenance (See M234 launcher maintenance instructions)	
Major components, location and description	1-3
Manifold:	
Cleaning.....	2-15
Installation.....	2-23
Location	1-3
Lubrications.....	2-19
PMCS.....	2-5
Removal.....	2-12
Manifold retaining pin:	
Cleaning.....	2-16
Installation.....	2-24
Location	1-3
Lubrications.....	2-19
PMCS.....	2-5
Removal.....	2-11
Troubleshooting	2-6
Manifold seating warning.....	inside front cover
Manual overview.....	iii

Subject	Page
M	
Materials and supplies, expendable, list of.....	D-2
M16A1 rifle	1-3
M234 launcher:	
Characteristics, capabilities and features	1-3
List of tasks	2-10
Location and description of major components	1-3
Maintenance instructions:	
Cleaning	2-15
Disassembly	2-11
Initial setup	2-11
Inspection	2-18
List of tasks	2-10
Lubrication	2-18
PMCS	2-5
Preparation for storage or shipment.....	2-25
Purpose	1-1
Reassembly.....	2-19
Repair.....	2-18
Service upon receipt.....	2-2
Troubleshooting.....	2-6
N	
National stock number and part number index	C-6
Nomenclature cross-reference list	1-2
Nomenclature, official.....	1-2
O	
Official nomenclature, names, and designations	1-2
Overview, manual.....	iii

Subject	Page
P	
Part number index	C-6
PMCS	2-3
Preparation for storage or shipment.....	2-25
Preventive maintenance checks and services (PMCS).....	2-3
Procedure, summary	2-10
Projectile (troubleshooting).....	2-6
Purpose of equipment	1-1
R	
Rear sight	1-3
Reassembly.....	2-19
Recommendations, reporting	1-2
Records and reports (forms)	1-1
References	A-1
Removal (See individual part)	
Repair	2-18
Repair parts and special tools list.....	C-1
Repair parts list.....	C-4
Reporting accidents.....	1-1

Subject	Page
R	
Reporting equipment improvement recommendations (EIR)	1-2
Reporting errors and recommending improvements	i
Reports (Forms)	1-1
Retainer:	
Cleaning	2-17
Installation	2-22
Lubrication	2-19
PMCS	2-4
Removal	2-12
Retaining plate:	
Cleaning	2-17
Installation	2-19
PMCS	2-5
Removal	2-12
Retaining ring:	
Cleaning	2-17
Installation	2-19
PMCS	2-5
Removal	2-14
Retaining ring wedge	2-14
Rifle bayonet stud	1-3
Rifle forward sight guard	1-3

Subject	Page
S	
Scope	1-1
Service upon receipt	2-2
Setup, initial	2-10
Shaft:	
Cleaning	2-15
PMCS	2-4
Shipment or storage, preparation for	2-25
Special tools, TMDE, and support equipment	2-1
Stop screw:	
Installation	2-22
PMCS	2-5
Removal	2-12
Summary procedure	2-10
Support equipment	2-1
Symptom index	2-6
T	
Table of contents	i
Tasks, list of	2-10
Technical manuals	A-1

Subject **Page**

T

TMDE2-1

Tool and test equipment and requirements for M234
launcher (MAC) B-4

Tools and equipment, common2-1

Troubleshooting::
Symptom index2-6
Troubleshooting table2-7

U

Unpacked equipment, checking2-3

Subject **Page**

W

Warning pageinside front cover

Washer:
Installation2-22
PMCS2-5
Removal2-12

Wedge, retaining ring2-14

By Order of the Secretary of the Army:

Official:

E. C. MEYER
General, United States Army
Chief of Staff

ROBERT M. JOYCE
Brigadier General, United States Army
The Adjutant General

DISTRIBUTION:

To be distributed in accordance with DA Form 12-40A, Organizational Maintenance requirements for Launchef, Riot Control, 64-MM, M234.

*U.S. GOVERNMENT PRINTING OFFICE 1993 O - 342-421 (62266)

PIN: 050285-000